

3 回転型だから微細な設定が簡単

3 回転型サーメットリマ 3 TURNS CERMET TRIMMERS

TM-7

RoHS 指令対応 RoHS compliant

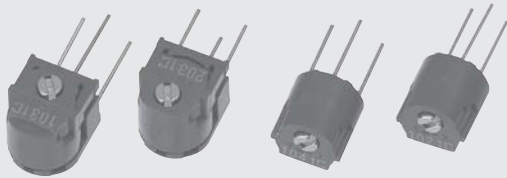

特長 FEATURES

- RoHS 指令対応
- 微細な設定が可能
- バックラッシュが最小(当社比)
- RoHS compliant
- Fine setting is possible
- Extremely small backlash (In house comparison)

内部構造図 INTERNAL STRUCTURE

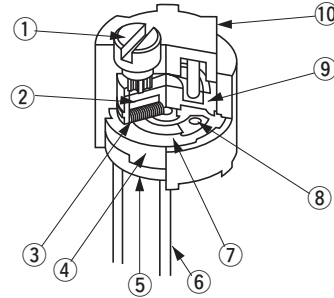

名称 Part name	材料 Material	燃焼性 Flammability
① シャフト Shaft	亜鉛合金、ニッケルめっき Zinc alloy, Nickel-plated	—
② ゴム板 Rubber cushion	シリコンゴム Silicone rubber	
③ ワイパ(摺動子) Wiper	多元合金 Multi metal alloy	—
④ ベースエレメント Base element	セラミック Ceramic	
⑤ 接着剤 Adhesive	エポキシ Epoxy	UL94V-0
⑥ 端子 Terminal pin	銅、錫めっき Copper, Tin-plated	—
⑦ 抵抗体 Resistive element	RuO ₂ サーメット RuO ₂ cermet	
⑧ 電極体 Electrode	Ag-Pd サーメット Ag-Pd cermet	UL94HB
⑨ ロータギア Rotor gear	PA(ポリアミド) Polyamide	
⑩ ハウジング Housing	PBT(ポリブチレンテレフタレート) Polybutyleneterephthalate	UL94V-0

型式表示 PART NUMBER DESIGNATION

TM - 7 EP 50 kΩ (503)

シリーズ名 Series name

端子 Terminal pin

E: 無鉛めっき品(鉛フリー対応) Sn (Lead-free)

製品形状 Product shape

P: 上面調整 Top adjustment S: 側面調整 Side adjustment
W: 上面調整 Top adjustment X: 側面調整 Side adjustment





抵抗値記号 Resistance code

抵抗値 Resistance value

※ご注文に際しては、型式一覧表をご確認ください。

Please refer to the LIST OF PART NUMBERS when placing orders.

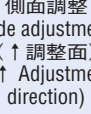
型式一覧表 LIST OF PART NUMBERS

調整方向 Adjustment position	端子形状 (上面図) Shape of terminal (Top view)	包装形態 Form of packaging	包装数量 Pieces in package
		ポリ袋 Plastic bag	
上面調整 Top adjustment 		TM-7EP	50 pcs./pack
		TM-7EW	
側面調整 Side adjustment (↑調整面) (↑ Adjustment direction) 		TM-7ES	
		TM-7EX	

〈公称抵抗値〉

<Nominal resistance values>

50 Ω	100 Ω	200 Ω	500 Ω	1 k Ω	2 k Ω	5 k Ω	10 k Ω
20 k Ω	50 k Ω	100 k Ω	200 k Ω	500 k Ω	1 M Ω	2 M Ω	

Fig. 1

※ ご注文に際しては、〈公称抵抗値〉(Fig. 1)について上記すべての組み合わせが標準品として用意しています。

※ ご注文に際しては、上記型式をご確認ください。

※ The above part numbers are all available as the standard item respectively with the combination of <Nominal resistance values> (Fig. 1).

※ Verify the above part numbers when placing orders.

電気的特性

ELECTRICAL CHARACTERISTICS

公称抵抗値範囲 Nominal resistance range	50 Ω ~ 2 M Ω
抵抗値許容差 Resistance tolerance	± 10 %
定格電力 Power ratings	0.5 W (70 °C) 0 W (120 °C)
抵抗変化特性 Resistance law	直線性 (B) Linear law
最大入力電圧 Maximum input voltage	DC300 V 又は定格電力の何れか小さい方 DC300 V or power rating, whichever is smaller
最大ワイパ電流 Maximum wiper current	100 mA 又は定格電力の何れか小さい方 100 mA or power rating, whichever is smaller
有効電気的回転数 Effective electrical turn	2.5 turns
残留抵抗値 End resistance	1 % 又は 2 Ω の何れか大きい方以下 1 % or 2 Ω, whichever is greater
接触抵抗変化 C.R.V.	1 % 又は 3 Ω の何れか大きい方以下 1 % or 3 Ω, whichever is greater
使用温度範囲 Operating temp. range	- 55 ~ 120 °C
抵抗温度係数 Temp. coefficient	± 100 10 ⁻⁶ /°C maximum
絶縁抵抗 Insulation resistance	1000 M Ω minimum (DC500 V)
絶縁耐圧 Dielectric strength	AC900 V, 60 s
質量 Net weight	Approx. 0.50 g (TM-7EP, EW) Approx. 0.69 g (TM-7ES, EX)

機械的特性

MECHANICAL CHARACTERISTICS

調整ネジ回転数 Mechanical turn	3 turns
回転トルク Operating torque	20 mN·m {204 gf·cm} maximum
回転止 Mechanical stop	クラッチ動作 Clutch action
回転寿命 Rotational life	200 cycles Δ R/R ≤ ± (2 Ω + 3 %)
端子強度 Terminal strength	10 N {1.02 kgf} minimum (引張り強さ Tensile strength)
操作部の押し強さ Thrust to shaft	10 N {1.02 kgf} minimum
はんだ付け性 Solderability	245 ± 3 °C, 2 ~ 3 s

{ } : 参考値 Reference only

環境特性

ENVIRONMENTAL CHARACTERISTICS

試験項目 Test item	試験条件 Test conditions	仕様 Specifications
熱衝撃 Thermal shock	- 65 ~ 125 °C (0.5 h), 5 cycles	[Δ R/R ≤ 1 %] [S.S. ≤ 1 %]
耐湿性 Humidity	- 10 ~ 65 °C (相対湿度 80 ~ 98 %), 10 cycles, 240 h	[Δ R/R ≤ 2 %]
耐衝撃性 Shock	981 m/s ² , 6 ms 6 directions for 3 times each	[Δ R/R ≤ 1 %] [S.S. ≤ 1 %]
耐振動性 Vibration	振幅 (Amplitude) 1.52 mm or 加速度 (Acceleration) 196 m/s ² , 10 ~ 2000 Hz, 3 directions, 12 times each	
負荷寿命 Load life	70 °C, 0.5 W, 1000 h	[Δ R/R ≤ 3 %] [S.S. ≤ 1 %]
低温動作 Low temp. operation	- 55 °C, 2 h	[Δ R/R ≤ 2 %] [S.S. ≤ 2 %]
高温放置 High temp. exposure	120 °C, 250 h	[Δ R/R ≤ 3 %] [S.S. ≤ 2 %]
耐水、密閉性 Immersion seal	85 °C, 60 s	もれ無し (連続気泡無し) No leaks (No continuous bubbles)
はんだ耐熱性 Soldering heat	フロー : Flow 260 ± 3 °C, 5 ~ 6 s, two times maximum 手はんだ : Manual soldering 380 ± 10 °C, 3 ~ 4 s	[Δ R/R ≤ 1 %]

Δ R/R : 全抵抗値変化 Change in total resistance
S.S. : 設定安定度 Setting stability

TM-7 CERMET TRIMMERS

最大入力定格 MAXIMUM INPUT RATINGS

公称抵抗値 Nominal resistance values (Ω)	抵抗値記号 Resistance code	最大入力電圧 Maximum input voltage (V)	最大ワイパ電流 Maximum wiper current (mA)
50	500	5.00	100
100	101	7.07	70.7
200	201	10.0	50.0
500	501	15.8	31.6
1 k	102	22.4	22.4
2 k	202	31.6	15.8
5 k	502	50.0	10.0
10 k	103	70.7	7.07
20 k	203	100	5.00
50 k	503	158	3.16
100 k	104	224	2.24
200 k	204	300	1.50
500 k	504	300	0.60
1 M	105	300	0.30
2 M	205	300	0.15

外形寸法図 OUTLINE DIMENSIONS

Unless otherwise specified, tolerance: ± 0.3 (Unit: mm)

TM-7EP

上面調整 Top adjustment

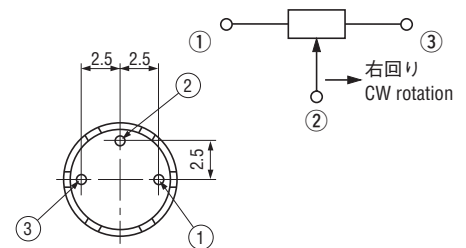
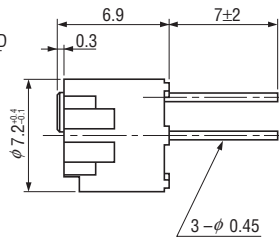
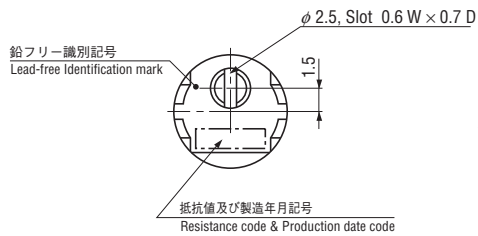

TM-7EW

上面調整 Top adjustment

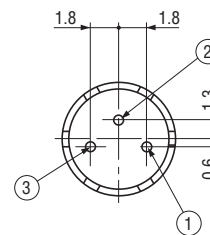
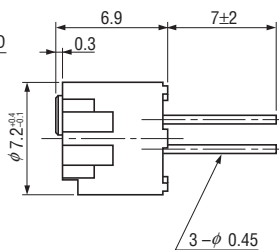
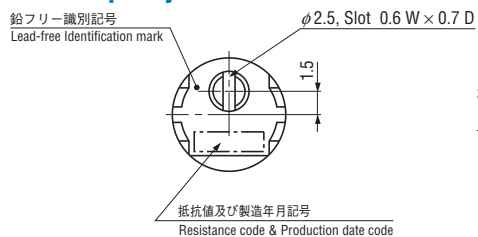

★ P型とピンピッチが異なります。
Pin pitch in W type is different from P type.

TM-7ES

側面調整 Side adjustment

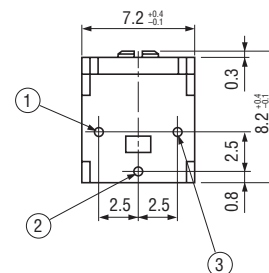
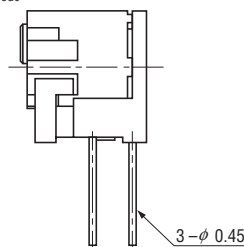
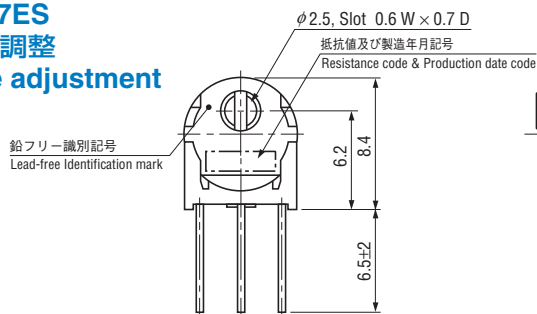

■外形寸法図 OUTLINE DIMENSIONS

● TM-7EX 側面調整 Side adjustment

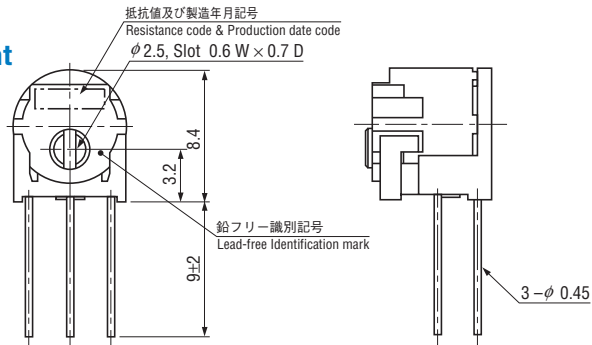

Unless otherwise specified, tolerance: ± 0.3 (Unit: mm)

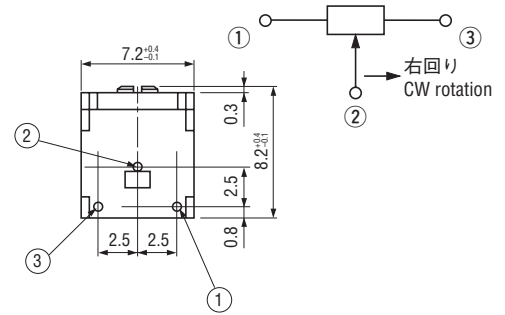

★ S 型とピン位置及びシャフト位置が異なります。
Pin position & shaft position of X type are different from S type.

■包装仕様

<ポリ袋の包装仕様>

- ポリ袋での包装は、50 個 / 袋となります。
- ポリ袋の箱詰めは、200 個を製品箱に包装致します。

■ PACKAGING SPECIFICATIONS

<Bulk pack specifications>

- Unit of bulk in a plastic bag is 50 pcs. per pack.
- Boxing of bulk in a plastic bag is performed with 200 pcs. per box.