



UM5100

Voice Processor

Features

- Voice recording and reproduction with external SRAM
- Voice reproduction with external EPROM or ROM
- Continuous variable slope Delta Modulation
- Max. addressable memory 256K
- Single 3V ~ 6V power operation
- Low power consumption by CMOS structure
- Inexpensive RC oscillation
- Adjustable bit rates from 10K to 28K bps.
- High quality voice reproduction
- Application for voice storage, security system, telecommunication and other voice fields

General Description

The UM5100 is a single chip CMOS LSI for voice recording and reproduction with SRAM or voice only production with EPROM or ROM. It is composed of RC oscillator, Address/data bus, series to parallel (and vice versa) converter, mode controller and delta modulation. The Delta modulation circuit is based on a continuous variable slope waveform by digital recording and reproduction of voice signals. For low frequency, there are auxiliary outputs to avoid distortion. For high frequency, there is an

internal amplifier, to intensify voice loudness. The RC oscillator is the best option in bit rates from 10K to 28K bps. Memory IC and Audio circuits which include a microphone, speaker, amplifier etc., are externally connected to complete the voice recording and reproducing module. All Input pins are CMOS compatible. Typical applications include voice storage, voice response, telecommunication and other voice fields.

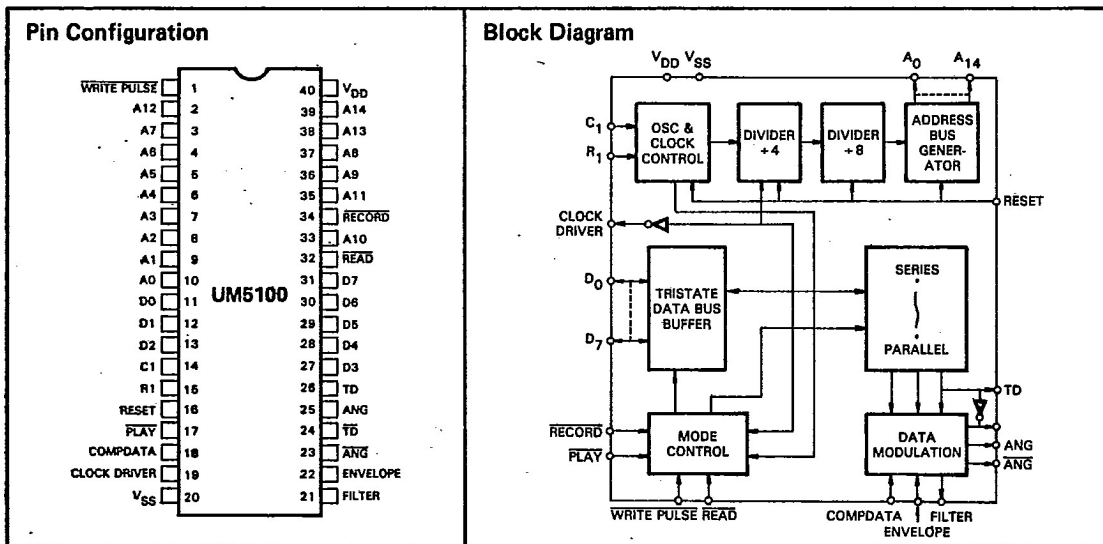

9325812 UNITED MICROELECTRONICS

92D 00448 D 7-77-13



UM5100

Absolute Maximum Ratings*

Supply Voltage, $V_{DD} - V_{SS}$ 0 to 7V
 Input Voltage, V_{IN} V_{SS} to V_{PD}
 Operating Temperature, T_{OP} $-10^{\circ}C$ to $60^{\circ}C$
 Storage Temperature, T_{ST} $-20^{\circ}C$ to $80^{\circ}C$

***Comments**

Stresses above those listed under "Absolute Maximum Ratings" may cause permanent damage to the device. This is a stress rating only and functional operation of the device at these or any other conditions above those indicated in the operational sections of this specification is not implied.

Electrical Characteristics

($V_{DD} = 5V$, $F_{OSC} = 40$ KHz, unless otherwise specified)

Symbol	Parameter	Limit			Units
		Min.	Typ.	Max.	
V_{DD}	Supply Voltage	3	5	6	V
I_{DD}	Stand-by Current		1.0		μA
I_{drive}	Clock Drive Current	16			mA
I_{sink}	Clock Sink Current	16			mA
V_{IH}	Input Voltage	High	3.5	5	V
V_{IL}		Low	0	1.5	V
I_{drive}	*Output Current	Drive	.3	4	mA
I_{sink}		Sink	3	4	mA
T_{Reset}	Reset Pulse	1			μS
T_{Write}	Write Pulse Width	200 NS		10 μS	

Note: *Except A_0 , D_6 pin.

Bonding Diagram

Pad No.	X	Y	Pad No.	X	Y
1	749	1208	21	-730	1208
2	539	1208	22	-520	1208
3	329	1208	23	-310	-1208
4	119	1208	24	-100	-1208
5	-91	1208	25	110	-1208
6	-301	1208	26	319	-1208
7	-511	1208	27	529	-1208
8	-721	1208	28	740	-1208
9	-931	1208	29	950	-1208
10	-1140	1208	30	1161	-1208
11	-1264	697	31	1264	-691
12	-1264	486	32	1264	-481
13	-1264	277	33	1264	-271
14	-1264	67	34	1264	-61
15	-1264	-143	35	1264	149
16	-1264	-354	36	1264	359
17	-1264	-564	37	1264	569
18	-1264	-774	38	1264	779
19	-1264	-984	39	1264	989
20	-956	1216	40	949	1208

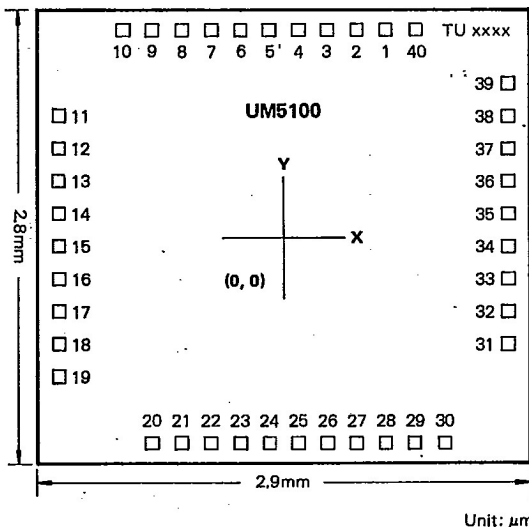



UM5100

Pin Description

V_{DD}

Positive power supply +3 ~ +6V operation voltage.

V_{SS}

Circuit GND potential.

A₀ ~ A₁₄

Address bus.

D₀ ~ D₇

Data bus.

RECORD

Input pin, active Low. Triggering this input pin the chip will go into "speech analysis" mode.

WRITE PULSE

Output pin, active Low. This pin generates one pulse each time the clock count advances eight cycles. This pin is active only in the "speech analysis" mode.

READ

Output pin, active Low. This pin provides an output control signal for external memory. This pin is active only in the "speech synthesis" mode.

PLAY

Input pin, active low. Triggering this pin, the chip will go into "speech synthesis" mode.

RESET

Input pin, active high. When activated, all the internal counters are cleared and the chip is disabled.

ANG and \overline{ANG}

Analogue voice signal outputs with opposite phase.

FILTER

Output pin. Produces envelope waveform with external integrator circuit.

ENVELOPE

Input pin. Envelope signal will go into this pin to modulate voice amplitude.

TD and \overline{TD}

Output pin. Auxiliary outputs for low frequency signal.

COMPDATA

Input pin. Detects the delta slope which is generated from the comparison of input signal and feedback signal.

C, R

RC oscillator pins, $f_{osc} = 40 \text{ KHz}$ for $R = 7.2K$ $C = 0.0047\mu f$

CLOCK DRIVER

Output pin for negative voltage generation.

Talk Back Application Block Diagram

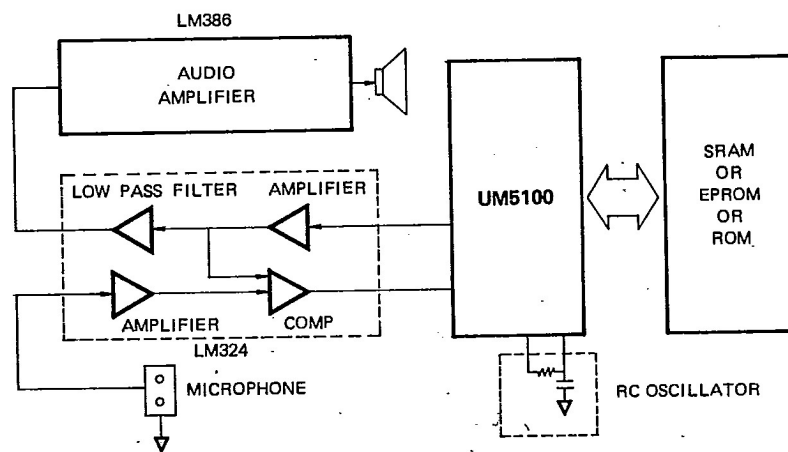

9325812 UNITED MICROELECTRONICS

92D 00450

D 7-77-13



UM5100

SPEECH RECORDING AND PLAYBACK

(With power switch)

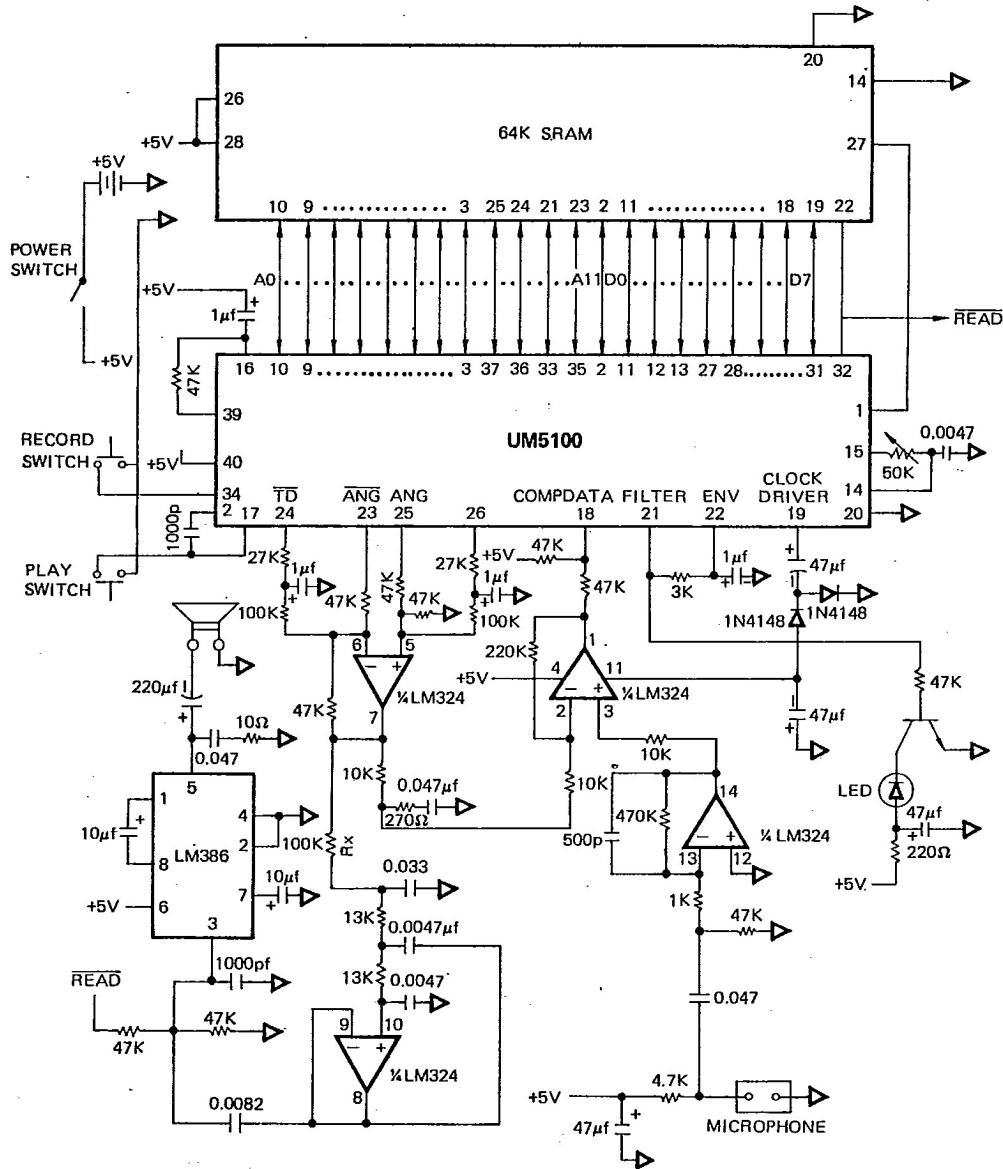



UM5100

Application Circuits

SPEECH RECORDING AND PLAYBACK

(With low standby current)

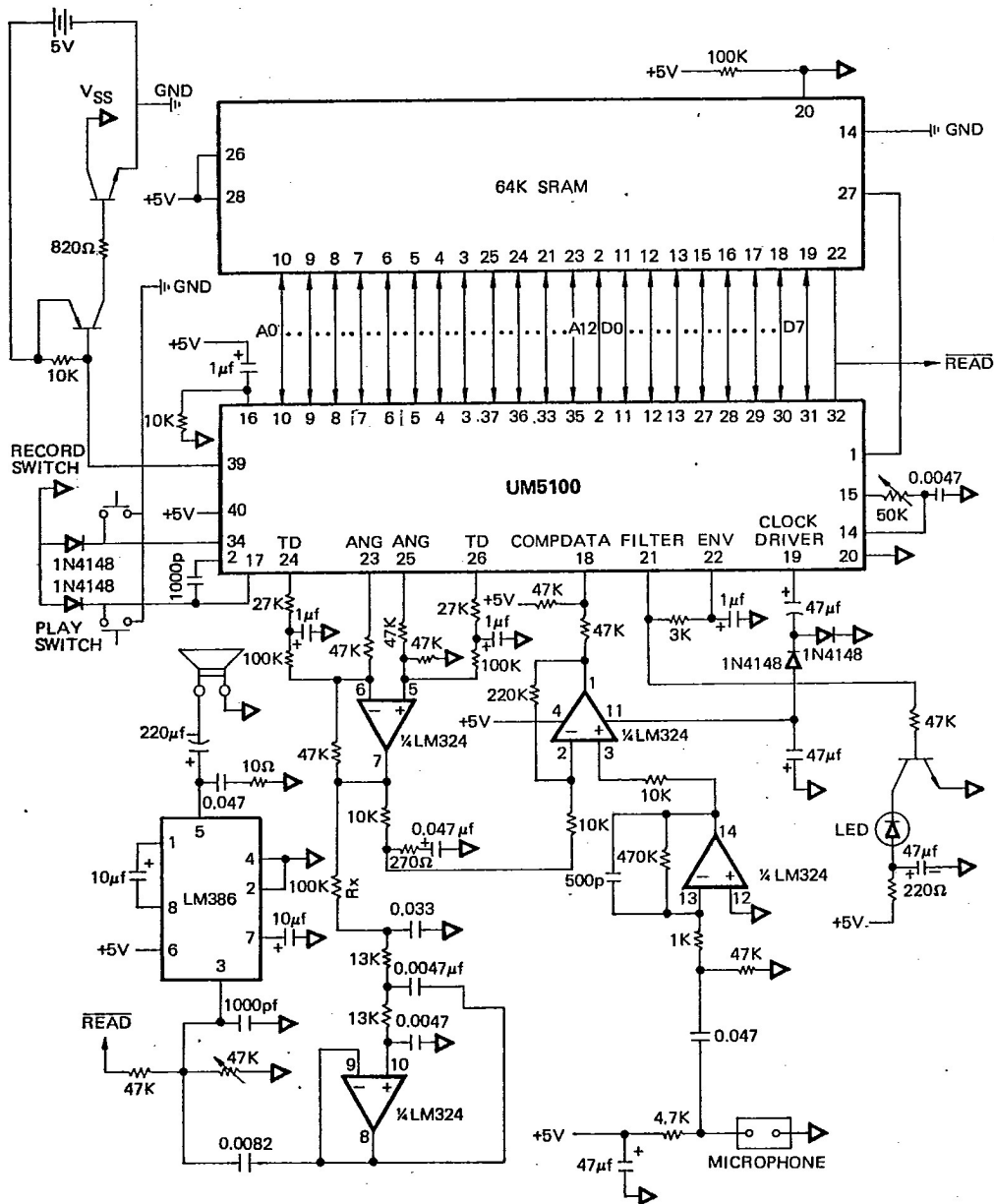



UM5100

SPEECH RECORDING AND PLAYBACK
(by voice trigger)

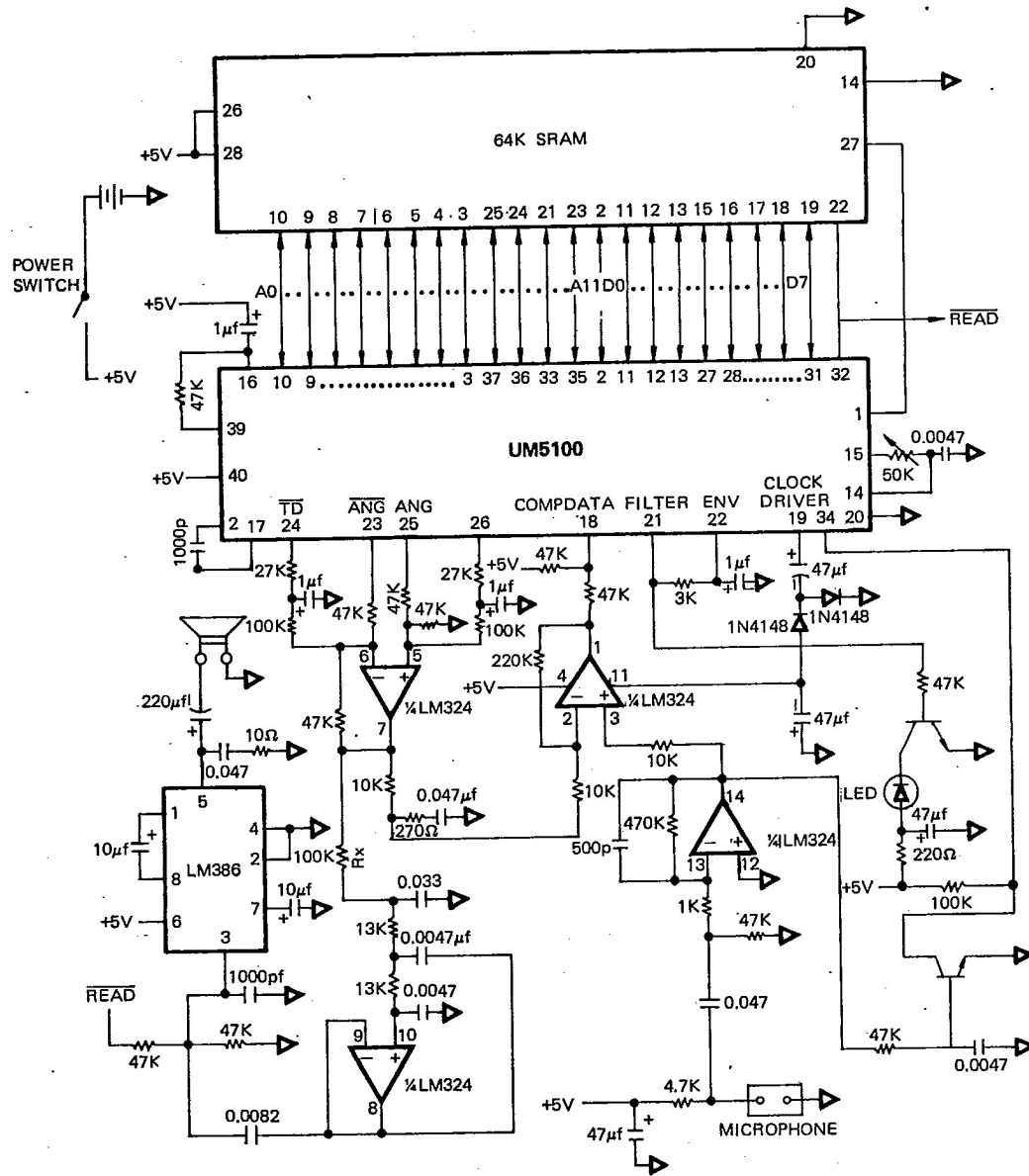

9325812 UNITED MICROELECTRONICS

92D 00453

D 7-77-13



UM5100

SPEECH RECORDING AND PLAYBACK
(With 16K SRAM x 2)

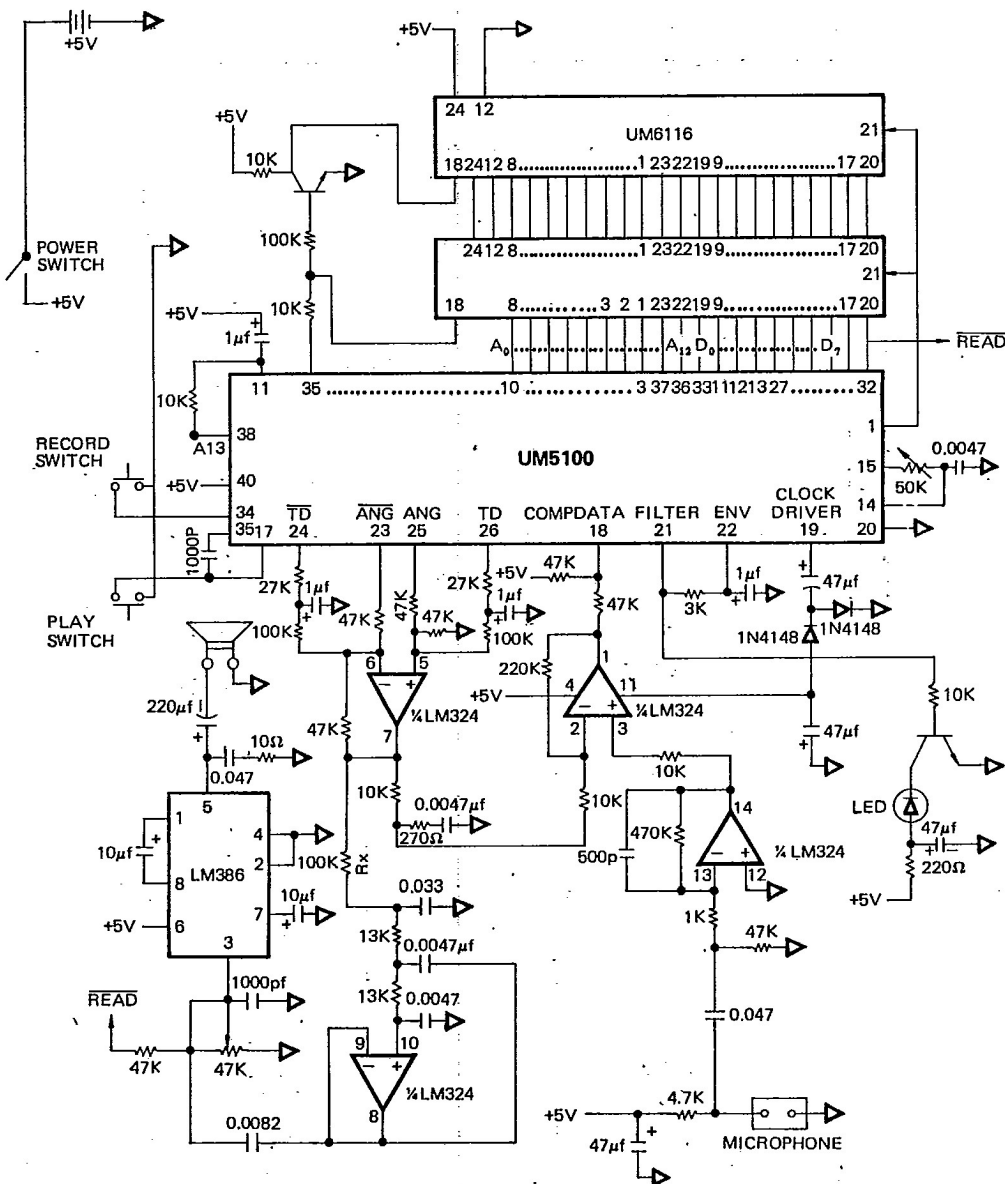

9325812 UNITED MICROELECTRONICS

92D 00454

D 7-77-13



UM5100

SPEECH SYNTHESIS

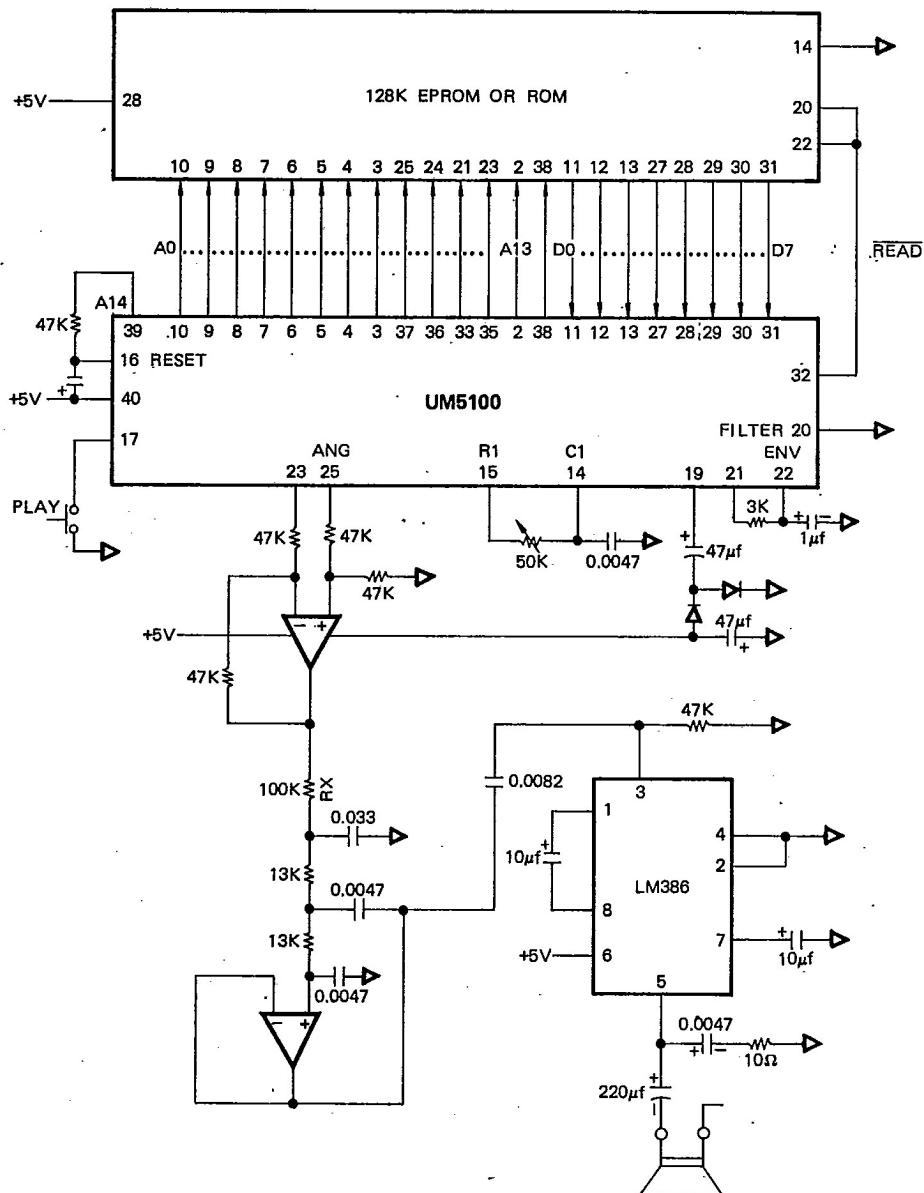

This datasheet has been download from:

www.datasheetcatalog.com

Datasheets for electronics components.