

● STR7000+SI-8020 Series

## STR7000+SI-8020 Series

# Separate Excitation Switching Type

### ■ Features

- High output current (6A:STR7000 series, 12A: STR7100 series)
- High efficiency (70 to 90%)
- Wide DC input voltage range
- Built-in drooping type overcurrent protection circuit
- Foldback type overcurrent protection can be set externally.
- Output voltage adjustment
- Built-in reference oscillator (35kHz)
- Output ON/OFF control

### ■ Applications

- Electronic equipment

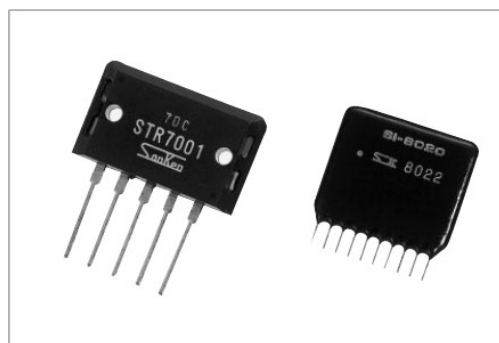

### ■ Lineup

$I_o$ (A) \ $V_o$ (V)	5	12	15	24
6	STR7001+SI-8020	STR7002+SI-8021	STR7002+SI-8022	STR7003+SI-8023
12	STR7101+SI-8020	STR7102+SI-8021	STR7102+SI-8022	STR7103+SI-8023

### ■ Absolute Maximum Ratings

#### Power Section: STR7000/STR7100 ( $T_a=25^\circ\text{C}$ )

Parameter	Symbol	Ratings		Unit
		STR7000 Series	STR7100 Series	
Power Transistor Breakdown Voltage	$V_{4-1}$	60		V
Drive Transistor Breakdown Voltage	$V_{4-5}$	60		V
Diode Breakdown Voltage	$V_{1-2}$	60		V
Collector Current	$I_c$	6(peak 7.5)	12(peak 15)	A
Power Dissipation	$P_{D1}$	100( $T_c=25^\circ\text{C}$ )		W
	$P_{D2}$	4.3(Without heatsink)		W
Power Transistor Thermal Resistance	$R_{th(j-c)}$	1.25	1.0	$^\circ\text{C}/\text{W}$
Power Transistor Junction Temperature	$T_j$	+150		$^\circ\text{C}$
Operating Temperature	$T_{OP}$	-30 to +125( $T_c$ )		$^\circ\text{C}$
Storage Temperature	$T_{Stg}$	-30 to +125		$^\circ\text{C}$

#### ■ Control Section: SI-8020 Series ( $T_a=25^\circ\text{C}$ )

Parameter	Symbol	Ratings	Unit
DC Input Voltage	$V_{IN}$	55	V
Power Dissipation	$P_D$	1	W
Operating Temperature	$T_{OP}$	-20 to +85	$^\circ\text{C}$
Storage Temperature	$T_{Stg}$	-20 to +100	$^\circ\text{C}$



● STR7000+SI-8020 Series

■ Electrical Characteristics: 6A Type

(Ta=25°C)

Parameter	Symbol	Ratings												Unit
		STR7001+SI-8020			STR7002+SI-8021			STR7002+SI-8022			STR7003+SI-8023			
		min.	typ.	max.	min.	typ.	max.	min.	typ.	max.	min.	typ.	max.	
DC Input Voltage Range	V <sub>IN</sub>	11		40	18		50	21		50	30		50	V
Output Voltage	V <sub>O</sub>	5.0	5.1	5.2	11.8	12.0	12.2	14.8	15.0	15.2	23.7	24.0	24.3	V
	Conditions	V <sub>IN</sub> =20V, I <sub>O</sub> =3.0A			V <sub>IN</sub> =27V, I <sub>O</sub> =3.0A			V <sub>IN</sub> =30V, I <sub>O</sub> =3.0A			V <sub>IN</sub> =40V, I <sub>O</sub> =3.0A			
Efficiency	?		72			84			86			90		%
	Conditions	V <sub>IN</sub> =20V, I <sub>O</sub> =3.0A			V <sub>IN</sub> =27V, I <sub>O</sub> =3.0A			V <sub>IN</sub> =30V, I <sub>O</sub> =3.0A			V <sub>IN</sub> =40V, I <sub>O</sub> =3.0A			
Switching Frequency	f		35			35			35			35		kHz
	Conditions	V <sub>IN</sub> =20V, I <sub>O</sub> =3.0A			V <sub>IN</sub> =27V, I <sub>O</sub> =3.0A			V <sub>IN</sub> =30V, I <sub>O</sub> =3.0A			V <sub>IN</sub> =40V, I <sub>O</sub> =3.0A			
Line Regulation	?V <sub>OLINE</sub>			80			120			150			200	mV
	Conditions	V <sub>IN</sub> =15 to 25V, I <sub>O</sub> =3.0A			V <sub>IN</sub> =22 to 32V, I <sub>O</sub> =3.0A			V <sub>IN</sub> =25 to 35V, I <sub>O</sub> =3.0A			V <sub>IN</sub> =35 to 45V, I <sub>O</sub> =3.0A			
Load Regulation	?V <sub>OLOAD</sub>			30			40			40			50	mV
	Conditions	V <sub>IN</sub> =20V, I <sub>O</sub> =1 to 5A			V <sub>IN</sub> =27V, I <sub>O</sub> =1 to 5A			V <sub>IN</sub> =30V, I <sub>O</sub> =1 to 5A			V <sub>IN</sub> =40V, I <sub>O</sub> =1 to 5A			
Ripple Rejection	R <sub>REJ</sub>		45			45			45			45		dB
	Conditions	f=100 to 120Hz			f=100 to 120Hz			f=100 to 120Hz			f=100 to 120Hz			
Overcurrent Protection Starting Current	I <sub>S1</sub>	6.0		7.5	6.0		7.5	6.0		7.5	6.0		7.5	A
Limited Current at Overcurrent Protection Operation	I <sub>S2</sub>	6.0		7.5	6.0		7.5	6.0		7.5	6.0		7.5	A
	Conditions	R <sub>S</sub> =0.02?			R <sub>S</sub> =0.02?			R <sub>S</sub> =0.02?			R <sub>S</sub> =0.02?			

■ Electrical Characteristics: 12A Type

(Ta=25°C)

Parameter	Symbol	Ratings												Unit
		STR7101+SI-8020			STR7102+SI-8021			STR7102+SI-8022			STR7103+SI-8023			
		min.	typ.	max.	min.	typ.	max.	min.	typ.	max.	min.	typ.	max.	
DC Input Voltage Range	V <sub>IN</sub>	11		40	18		50	21		50	30		50	V
Output Voltage	V <sub>O</sub>	5.0	5.1	5.2	11.8	12.0	12.2	14.8	15.0	15.2	23.7	24.0	24.3	V
	Conditions	V <sub>IN</sub> =20V, I <sub>O</sub> =6.0A			V <sub>IN</sub> =27V, I <sub>O</sub> =6.0A			V <sub>IN</sub> =30V, I <sub>O</sub> =6.0A			V <sub>IN</sub> =40V, I <sub>O</sub> =6.0A			
Efficiency	?		70			82			84			87		%
	Conditions	V <sub>IN</sub> =20V, I <sub>O</sub> =6.0A			V <sub>IN</sub> =27V, I <sub>O</sub> =6.0A			V <sub>IN</sub> =30V, I <sub>O</sub> =6.0A			V <sub>IN</sub> =40V, I <sub>O</sub> =6.0A			
Switching Frequency	f		35			35			35			35		kHz
	Conditions	V <sub>IN</sub> =20V, I <sub>O</sub> =6.0A			V <sub>IN</sub> =27V, I <sub>O</sub> =6.0A			V <sub>IN</sub> =30V, I <sub>O</sub> =6.0A			V <sub>IN</sub> =40V, I <sub>O</sub> =6.0A			
Line Regulation	?V <sub>OLINE</sub>			80			120			150			200	mV
	Conditions	V <sub>IN</sub> =15 to 25V, I <sub>O</sub> =6.0A			V <sub>IN</sub> =22 to 32V, I <sub>O</sub> =6.0A			V <sub>IN</sub> =25 to 35V, I <sub>O</sub> =6.0A			V <sub>IN</sub> =35 to 45V, I <sub>O</sub> =6.0A			
Load Regulation	?V <sub>OLOAD</sub>			30			40			40			50	mV
	Conditions	V <sub>IN</sub> =20V, I <sub>O</sub> =3 to 9A			V <sub>IN</sub> =27V, I <sub>O</sub> =3 to 9A			V <sub>IN</sub> =30V, I <sub>O</sub> =3 to 9A			V <sub>IN</sub> =40V, I <sub>O</sub> =3 to 9A			
Ripple Rejection	R <sub>REJ</sub>		45			45			45			45		dB
	Conditions	f=100 to 120Hz			f=100 to 120Hz			f=100 to 120Hz			f=100 to 120Hz			
Overcurrent Protection Starting Current	I <sub>S1</sub>	12		15	12		15	12		15	12		15	A
Limited Current at Overcurrent Protection Operation	I <sub>S2</sub>	12		15	12		15	12		15	12		15	A
	Conditions	R <sub>S</sub> =0.01?			R <sub>S</sub> =0.01?			R <sub>S</sub> =0.01?			R <sub>S</sub> =0.01?			



● STR7000+SI-8020 Series

■ Outline Drawing

(unit: mm)

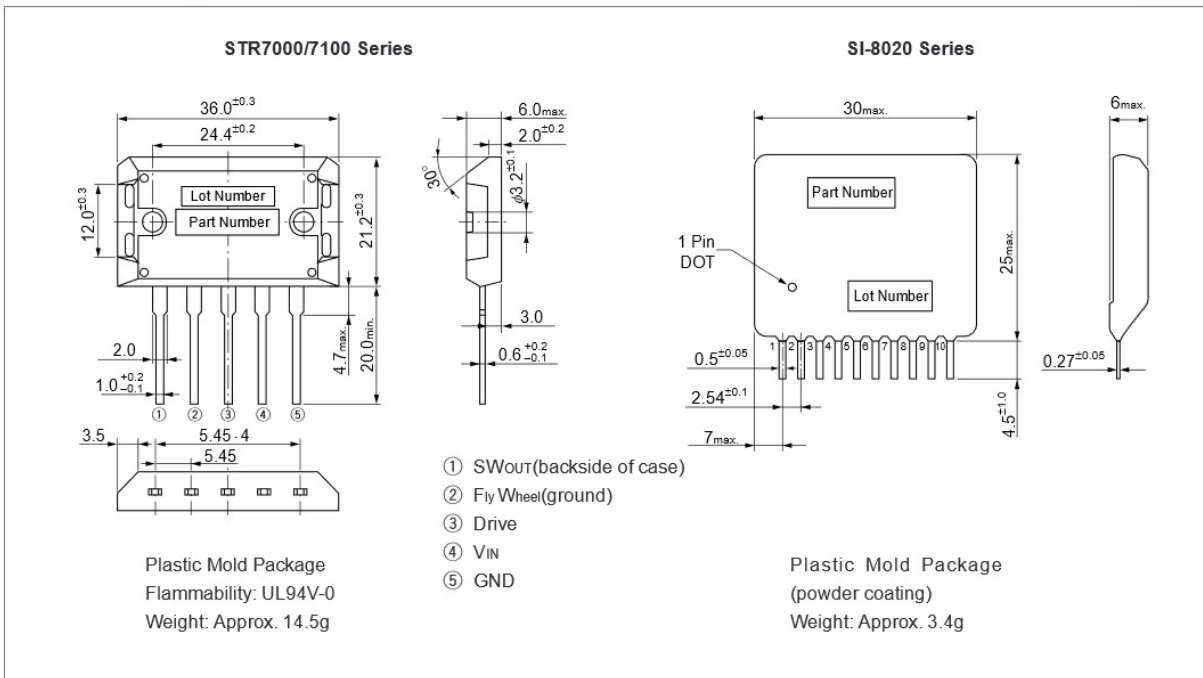

■ Block Diagram

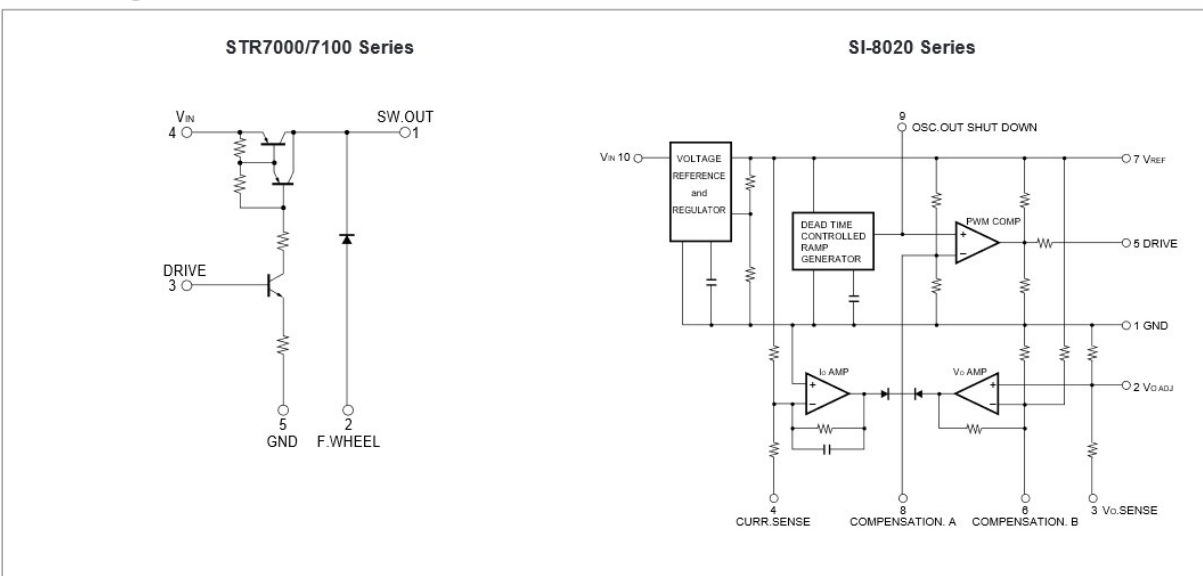



■ Standard External Circuit

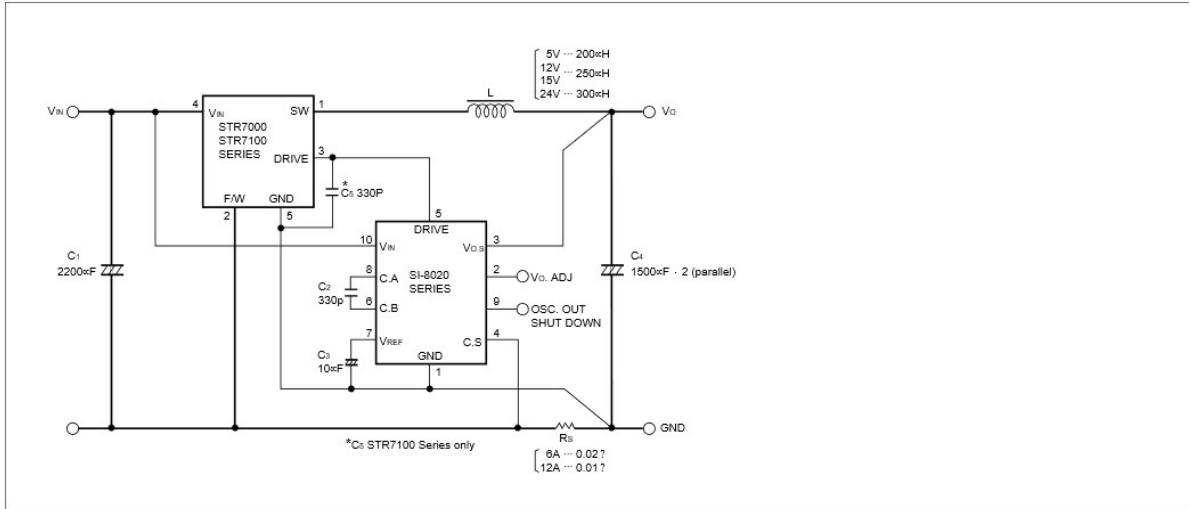

■ Notes of Pattern Design

- 1) Thick lines in the Standard External Circuit are lines through which a large current flows. Make these pattern lines as thick as possible.
- 2) Place capacitor C1 on the input side as closely as possible to terminals no.2 and no.4 of the STR7000/7100 series. C1 may be used in combination with a smoothing capacitor for rectifying, but the above points must be taken into consideration. In cases where C1 is not provided or it is placed too far from the terminals stated above, abnormal oscillation due to poorer transient response or increased ringing may occur.
- 3) Connect voltage sensing terminal Vo.s and GND as closely as possible to output capacitor C4 (a current of approximately 1mA flows into Vo.s terminal). If they are placed too far from C4, abnormal oscillation due to decreased regulation or increased switching ripple may occur.
- 4) Connect current sensing terminal C.S and GND as closely as possible to the detection resistor Rs (a current of approximately 0.5mA flows from the CS terminal). If they are placed too far from Rs, a decrease of the overcurrent setting point due to the voltage drop in the pattern, or malfunction of protection circuit due to increased ringing may occur.

■ Ta-Pd Characteristics

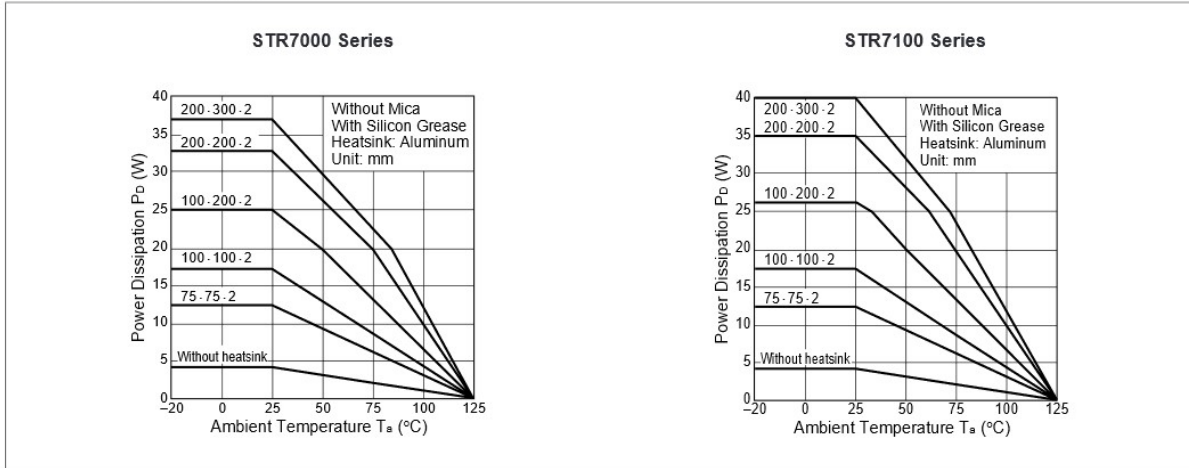





● STR7000+SI-8020 Series

■ Typical Characteristics

( $T_c=25^\circ\text{C}$ )

STR7001+SI-8020(5V)

Rise Characteristics

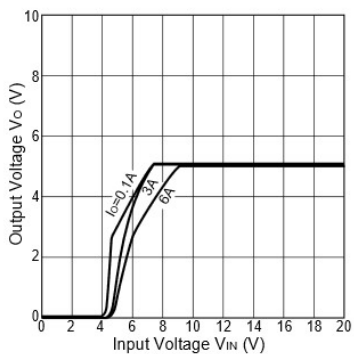

Efficiency Characteristics

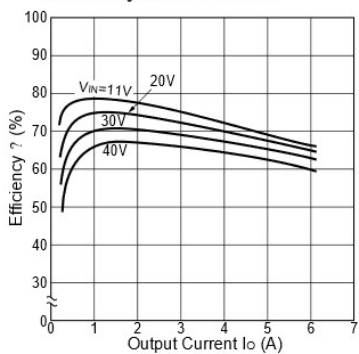

STR7002+SI-8021(12V)

Rise Characteristics

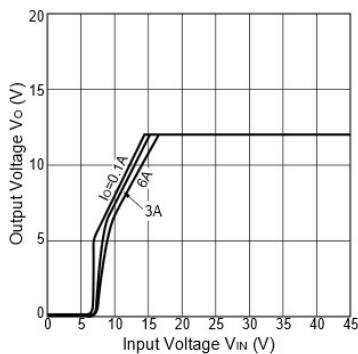

Efficiency Characteristics

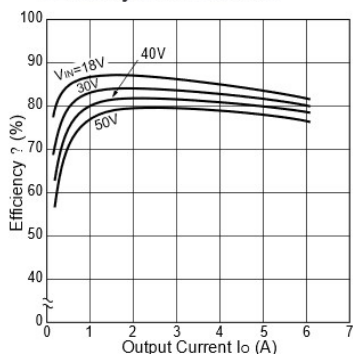

STR7003+SI-8023(24V)

Rise Characteristics

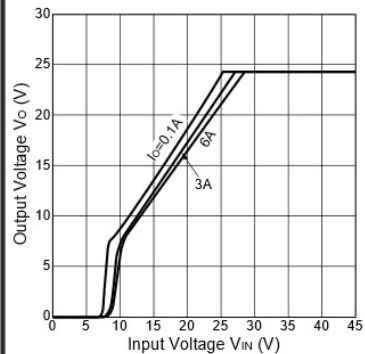

Efficiency Characteristics

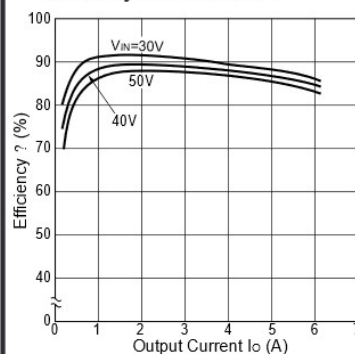

STR7101+SI-8020(5V)

Rise Characteristics

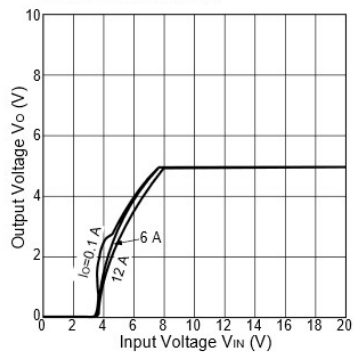

Efficiency Characteristics

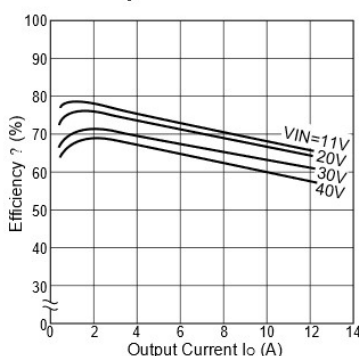

STR7102+SI-8021(12V)

Rise Characteristics

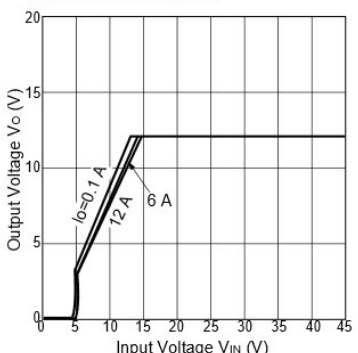

Efficiency Characteristics

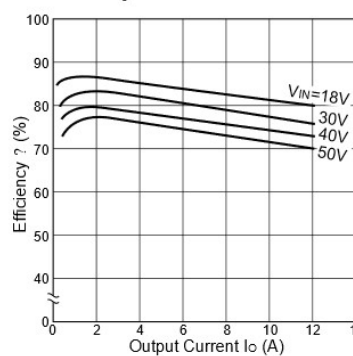

STR7103+SI-8023(24V)

Rise Characteristics

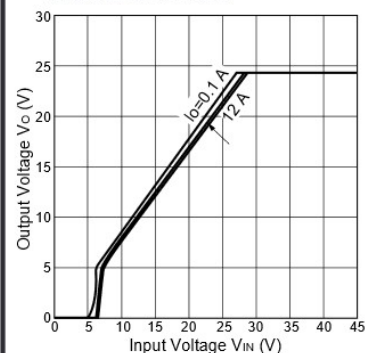

Efficiency Characteristics

