

# STR20000 Series

Switching Type — Chopper • Self Oscillation Type

## Features

- Requires only 4 external components
- Small size and high efficiency
- Low switching noise
- Variable output voltage
- Use of Sanken semiconductor components ensures high reliability

## Applications

- For power supplies in office equipment such as electronic typewriters, printers and copiers
- For power supplies in VCRs, personal CB radios (fixed stations), etc.

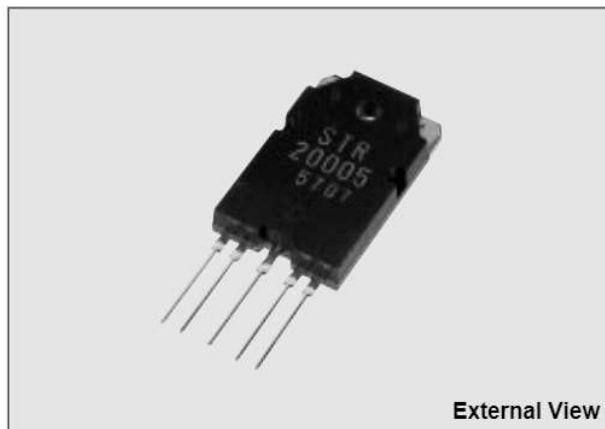

## ■ Absolute Maximum Ratings (Ta=25°C)

Parameter	Symbol	Ratings		Unit
		STR20005		
DC Input Voltage	V <sub>IN</sub>	45		V
DC Output Current	I <sub>o</sub>	2.0 (pulse 3.0)		A
Power Dissipation	P <sub>D</sub>	55 (T <sub>c</sub> =25°C)		W
		13 (T <sub>c</sub> =100°C)		
Operating Temperature	T <sub>op</sub>	-20 to +100		°C
Storage Temperature	T <sub>stg</sub>	-20 to +125		°C
Thermal Resistance (junction-to-case)	R <sub>th(j-c)</sub>	1.8		°C/W

## ■ Electrical Characteristics (Ta=25°C)

Parameter	Symbol	Ratings			Unit
		STR20005			
		min	typ	max	
DC Input Voltage Range	V <sub>IN</sub>	8		40	V
	Condition	I <sub>o</sub> =1.0A			
Output Voltage	V <sub>o</sub>	5.0	5.1	5.2	V
	Condition	V <sub>IN</sub> =20V, I <sub>o</sub> =1.0A			
Efficiency	η		72		%
	Condition	V <sub>IN</sub> =20V, I <sub>o</sub> =1.0A			
Line Regulation	ΔV <sub>OLINE</sub>			50	mV
	Condition	V <sub>IN</sub> =15 to 25V, I <sub>o</sub> =1.0A			
Load Regulation	ΔV <sub>OLOAD</sub>			100	mV
	Condition	V <sub>IN</sub> =20V, I <sub>o</sub> =0.5 to 1.5A			
Ripple Rejection	R <sub>REJ</sub>		45		dB
	Condition	f=100 to 120Hz			
Switching Frequency	f		30		kHz
	Condition	V <sub>IN</sub> =20V, I <sub>o</sub> =1.0A			

## ■ Outline Drawing/Terminal Connections (unit: mm)

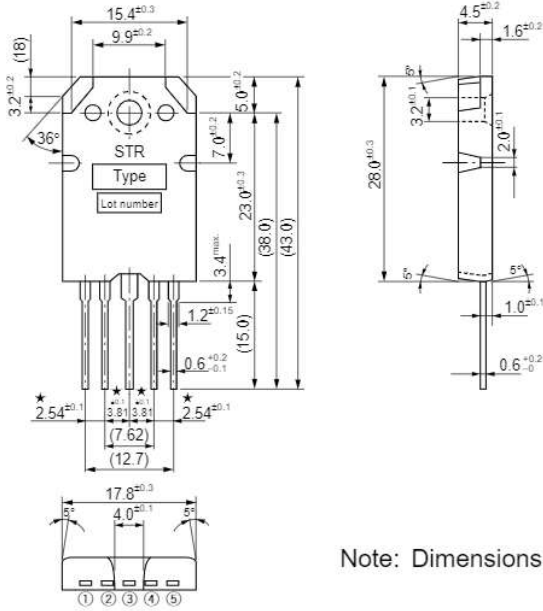

Plastic Mold Package Type  
Flammability: UL94V-0

### Terminal Connections

- ① Output Voltage Adjustment
- ② Output Voltage Detection
- ③ Switching Output (backside of case)
- ④ Input
- ⑤ Ground

Weight: Approx. 8.2 g

Note: Dimensions marked with \* are measured at the roots of the leads.

## ■ Block Diagram

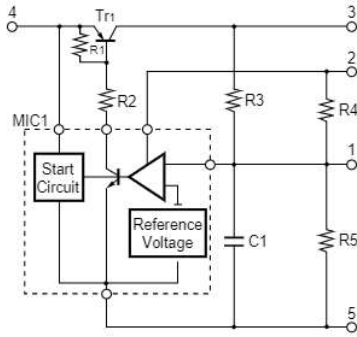

## ■ Standard External Circuit

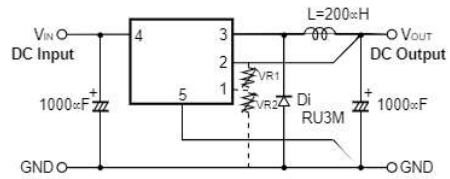

Use VR<sub>1</sub> and VR<sub>2</sub> only when adjusting the output voltages.

VR<sub>1</sub> : V<sub>out</sub> down

VR<sub>2</sub> : V<sub>out</sub> up

RU3M forward voltage : 0.7V

## ■ Typical Operating Characteristics

### Rise Characteristics

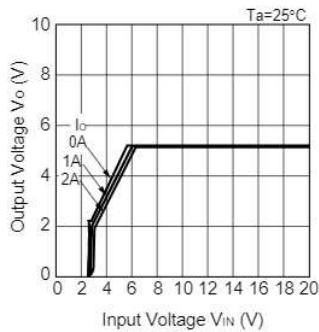

### Efficiency Characteristics

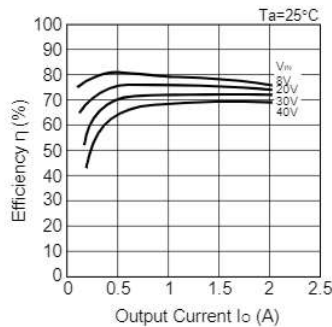

### Ta-PD Characteristics

