



Order this document by MC3401

# MC34017

## Telephone Tone Ringer Bipolar Linear/I<sup>2</sup>L

- Complete Telephone Bell Replacement Circuit with Minimum External Components
- On-Chip Diode Bridge and Transient Protection
- Direct Drive for Piezoelectric Transducers
- Push Pull Output Stage for Greater Output Power Capability
- Base Frequency Options – MC34017-1: 1.0 kHz  
– MC34017-2: 2.0 kHz  
– MC34017-3: 500 Hz
- Input Impedance Signature Meets Bell and EIA Standards
- Rejects Rotary Dial Transients

### TELEPHONE TONE RINGER BIPOLAR LINEAR/I<sup>2</sup>L

#### SEMICONDUCTOR TECHNICAL DATA



**D SUFFIX**  
PLASTIC PACKAGE  
CASE 751



**P SUFFIX**  
PLASTIC PACKAGE  
CASE 626

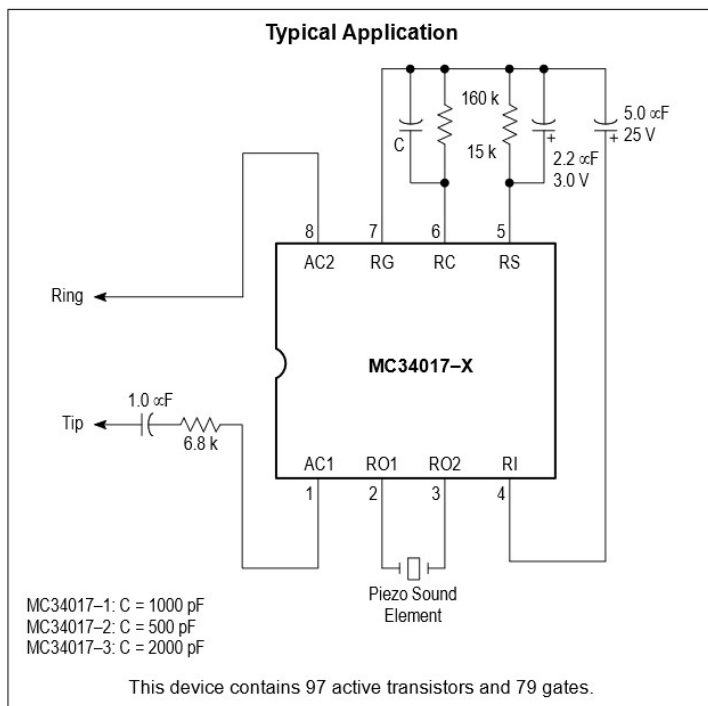

#### PIN CONNECTIONS

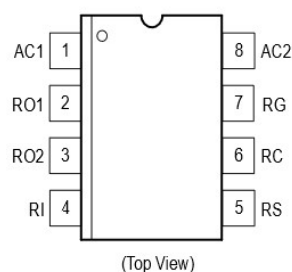

#### ORDERING INFORMATION

Device	Operating Temperature Range	Package
MC34017D	T <sub>A</sub> = -20° to +60°C	SOIC
MC34017P		Plastic DIF

♥ Motorola, Inc. 1996

## MC34017

### MAXIMUM RATINGS (Voltages Referenced to RG, Pin 7)

Rating	Symbol	Value	Unit
Operating AC Input Current (Pins 1, 8)	–	20	mA, RMS
Transient Input Current (Pins 1, 8) (T < 2.0 ms)	$V_{in}$	±300	mA, peak
Voltage Applied at RC (Pin 6)	$V_{RC}$	5.0	V
Voltage Applied at RS (Pin 5)	$V_{RS}$	5.0	V
Voltage Applied to Outputs (Pins 2, 3)	$V_O$	–2.0 to $V_{RI}$	V
Power Dissipation (@ 25°C)	$P_D$	1.0	W
Operating Ambient Temperature	$T_A$	–20 to +60	°C
Storage Temperature	$T_{stg}$	–65 to +150	°C

**NOTE:** ESD data available upon request.

### ELECTRICAL CHARACTERISTICS ( $T_A = 25^\circ\text{C}$ )

Characteristic	Test	Symbol	Min	Typ	Max	Uni
Ringing Start Voltage $V_{Start} = V_I$ at Ring Start $V_I > 0$ $V_I < 0$	1a 1b	$V_{Start} (+)$ $V_{Start} (-)$	34 –34	37.5 –37.5	41 –41	V <sub>dr</sub>
Ringing Stop Voltage $V_{Stop} = V_I$ at Ring Stop MC34017–1 MC34017–2 MC34017–3	1c	$V_{Stop}$	14 12 14	16 14 16	22 20 22	V <sub>dr</sub>
Output Frequencies ( $V_I = 50$ V) MC34017–1 High Tone Low Tone Warble Tone MC34017–2 High Tone Low Tone Warble Tone MC34017–3 High Tone Low Tone Warble Tone	1d	$f_H$ $f_L$ $f_W$ $f_H$ $f_L$ $f_W$ $f_H$ $f_L$ $f_W$	937 752 11.5 1874 1504 11.5 937 752 23	1010 808 12.5 2020 1616 12.5 1010 808 25	1083 868 14 2166 1736 14 1083 868 28	Hz
Output Voltage ( $V_I = 50$ V)	6	$V_O$	34	37	43	V <sub>pt</sub>
Output Short-Circuit Current	2	$I_{RO1}, I_{RO2}$	35	60	80	mA <sub>sc</sub>
Input Diode Voltage ( $I_I = 5.0$ mA)	3	$V_D$	5.4	6.2	6.8	V <sub>dr</sub>
Input Voltage – SCR “Off” ( $I_I = 30$ mA)	4a	$V_{off}$	30	38	43	V <sub>dr</sub>
Input Voltage – SCR “On” ( $I_I = 100$ mA)	4b	$V_{on}$	3.2	4.1	6.0	V <sub>dr</sub>
RS Clamp Voltage ( $V_I = 50$ V)	5	$V_{clamp}$	1.3	1.5	1.8	V <sub>dr</sub>

### PIN FUNCTION DESCRIPTION

Pin	Symbol	Description
1, 8	AC1, AC2	The input terminals to the full-wave diode bridge. The ac ringing signal from the telephone line energizes the ringer through this bridge.
5	RS	The input of the threshold comparator to which diode bridge current is mirrored and sensed through an external resistor (R3). Nominal threshold is 1.2 V. This pin internally clamps at 1.5 V.
4	RI	The positive supply terminal for the oscillator, frequency divider and output buffer circuits.
2, 3	RO1, RO2	The tone ringer output terminals through which the sound element is driven.
7	RG	The negative terminal of the diode bridge and the negative supply terminal of the tone generating circuitry.
6	RC	The oscillator terminal for the external resistor and capacitor which control the tone ringer frequencies (R2, C2).

### MC34017

#### APPLICATION CIRCUIT PERFORMANCE (Refer to Typical Application)

Characteristic	Typical Value	Units
Output Tone Frequencies		Hz
MC34017-1	808/1010	
MC34017-2	1616/2020	
MC34017-3	404/505	
Warble Frequencies	12.5	
Output Voltage ( $V_I = 60$ Vrms, 20 Hz)	37	Vpp
Output Duty Cycle	50	%
Ringing Start Input Voltage (20 Hz)	36	Vrms
Ringing Stop Input Voltage (20 Hz)	21	Vrms
Maximum AC Input Voltage (= 68 Hz)	150	Vrms
Impedance When Ringing		k $\Omega$
$V_I = 40$ Vrms, 15 Hz	>16	
$V_I = 130$ Vrms, 23 Hz	12	
Impedance When Not Ringing		k $\Omega$
$V_I = 10$ Vrms, 24 Hz	28	
$V_I = 2.5$ Vrms, 24 Hz	>1.0	M $\Omega$
$V_I = 10$ Vrms, 5.0 Hz	55	k $\Omega$
$V_I = 3.0$ Vrms, 200 - 3200 Hz	>200	k $\Omega$
Maximum Transient Input Voltage ( $T = 2.0$ ms)	1500	V
Ringer Equivalence: Class A	0.5	-
Class B	0.9	-

#### Block Diagram

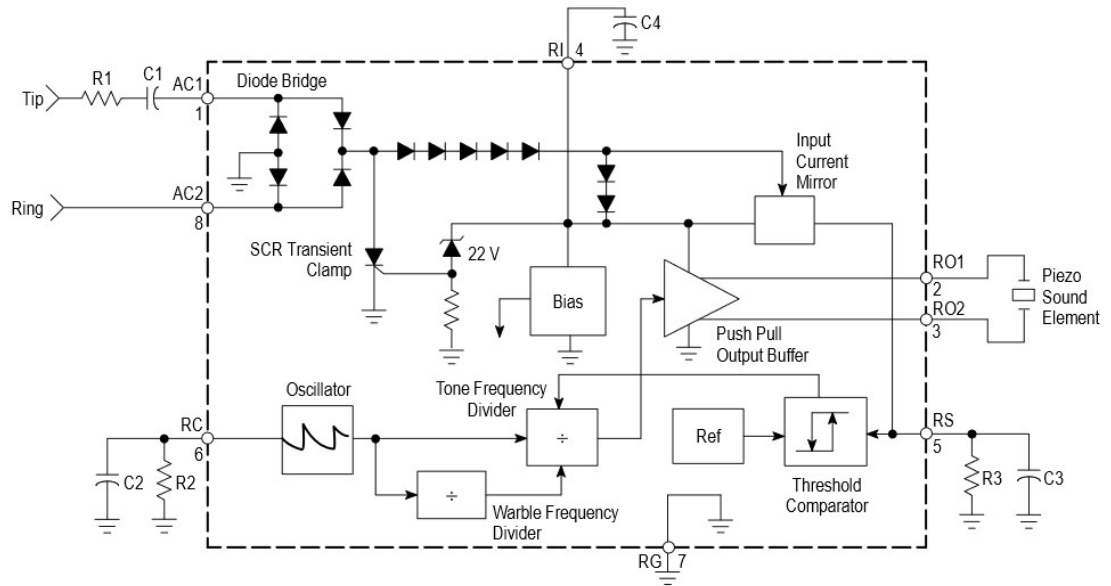

## MC34017

### CIRCUIT DESCRIPTION

The MC34017 Tone Ringer derives its power supply by rectifying the ac ringing signal. It uses this power to activate a tone generator and drive a piezo-ceramic transducer. The tone generation circuitry includes a relaxation oscillator and frequency dividers which produce high and low frequency tones as well as the tone warble frequency. The relaxation oscillator frequency  $f_o$  is set by resistor R2 and capacitor C2 connected to Pin RC. The oscillator will operate with  $f_o$  from 1.0 kHz to 10 kHz with the proper choice of external components (see Figure 1).

The frequency of the tone ringer output signal at RO1 and RO2 alternates between  $f_o/4$  to  $f_o/5$ . The warble rate at which the frequency changes is  $f_o/320$  for the MC34017-1,  $f_o/640$  for the MC34017-2 and  $f_o/160$  for the MC34017-3. With a 4.0 kHz oscillator frequency, the MC34017-1 produces 800 Hz and 1000 Hz tones with a 12.5 Hz warble rate. The MC34017-2 generates 1600 Hz and 2000 Hz tones with a similar 12.5 Hz warble frequency from an 8.0 kHz oscillator frequency. The MC34017-3 will produce 400 Hz and 500 Hz tones with a 12.5 Hz warble rate from a 2.0 kHz oscillator frequency. The tone ringer output circuit can source or sink 20 mA with an output voltage swing of 37 V peak-to-peak. Volume control is readily implemented by adding a variable resistance in series with the piezo transducer.

Input signal detection circuitry activates the tone ringer output when the ac line voltage exceeds programmed threshold level. Resistor R3 determines the ringing signal amplitude at which an output signal at RO1 and RO2 will be generated. The ac ringing signal is rectified by the internal diode bridge. The rectified input signal produces a voltage across R3 which is referenced to RG. The voltage across resistor R3 is filtered by capacitor C3 at the input to the threshold circuit.

When the voltage on capacitor C3 exceeds 1.2 V, threshold comparator enables the tone ringer output. I transients produced by pulse dialing telephones do not charge capacitor C3 sufficiently to activate the tone ringer output.

Capacitors C1 and C4 and resistor R1 determine the 120 Hz signature test impedance. C4 also provides filtering the output stage power supply to prevent droop in the square wave output signal. Six diodes in series with the rectifier bridge provide the necessary non-linearity for the 2.4 kHz signature tests.

An internal shunt voltage regulator between the RI and terminals provides dc voltage to power the output stage oscillator and frequency dividers. The dc voltage at F is limited to approximately 22 V in regulation. To protect the IC from telephone line transients, an SCR is triggered when regulator current exceeds 50 mA. The SCR diverts current from the shunt regulator and reduces the power dissipation within the IC.

### EXTERNAL COMPONENTS

R1	<b>Line Input Resistor</b> R1 affects the tone ringer input impedance. It also influences ringing threshold voltage and limits current from line transients. (Range: 2.0 to 10 k $\Omega$ ).
C1	<b>Line Input Capacitor</b> C1 ac couples the tone ringer to the telephone line and controls ringer input impedance at low frequencies. (Range: 0.4 to 2.0 $\mu$ F).
R2	<b>Oscillator Resistor</b> (Range: 150 to 300 k $\Omega$ ).
C2	<b>Oscillator Capacitor</b> (Range: 400 to 3000 pF).
R3	<b>Input Current Sense Resistor</b> R3 controls the ringing threshold voltage. Increasing R3 decreases the ring-start voltage. (Range: 5.0 to 18 k $\Omega$ ).
C3	<b>Ringing Threshold Filter Capacitor</b> C3 filters the ac voltage across R3 at the input of the ringing threshold comparator. It also provides dialer transient rejection. (Range: 0.5 to 5.0 $\mu$ F).
C4	<b>Ringer Supply Capacitor</b> C4 filters supply voltage for the tone generator circuits. It also provides an ac current path for the 10 Vrms ringer signature impedance. (Range: 1.0 to 10 $\mu$ F).

Figure 1. Oscillator Period ( $1/f_o$ ) versus Oscillator R2 C2 Product

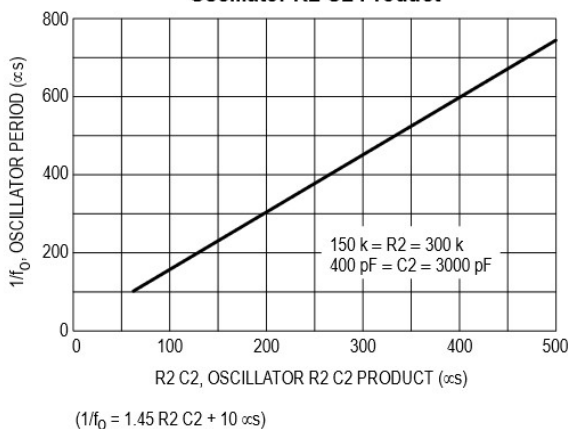

### MC34017

Figure 2. Test One

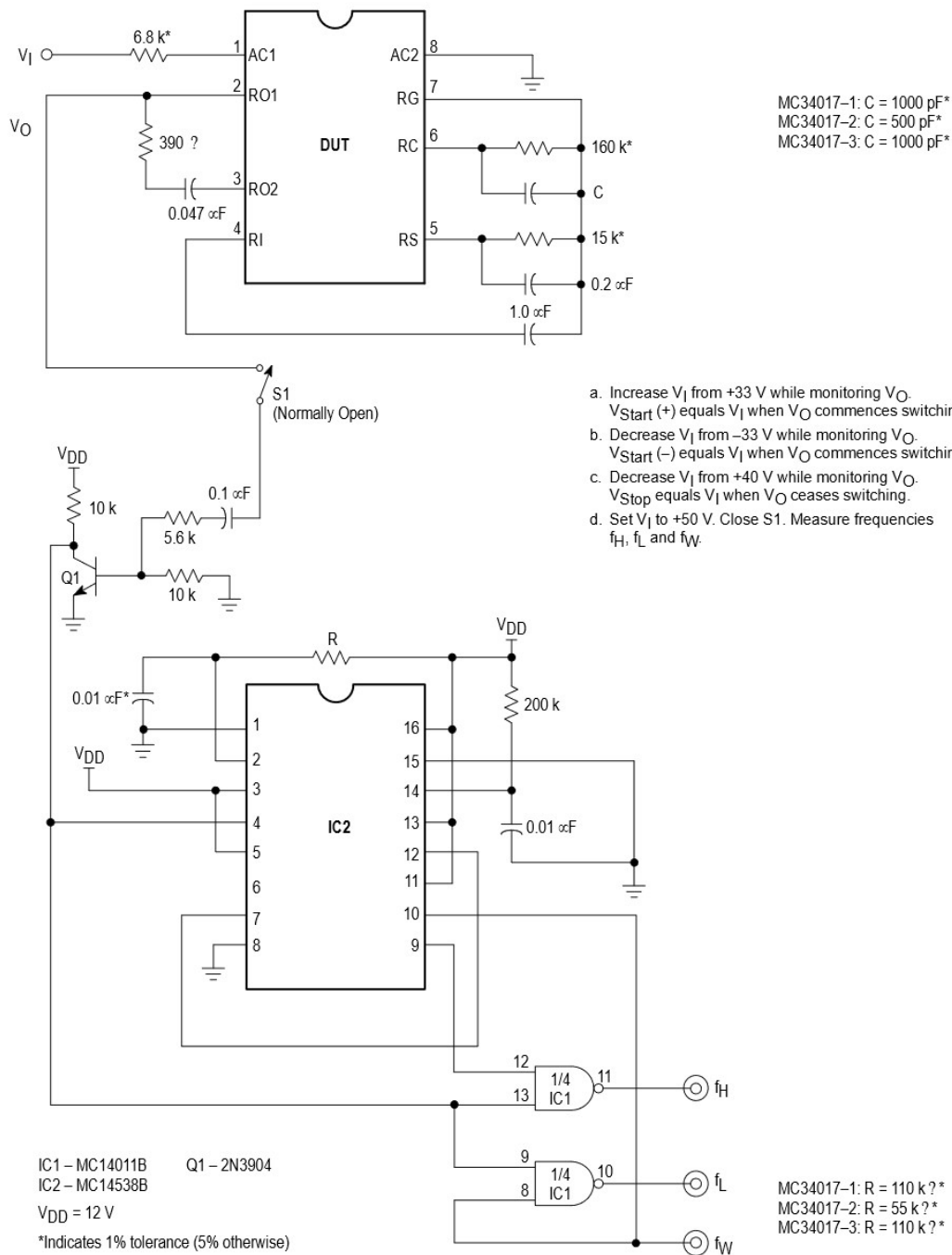

### MC34017

Figure 3. Test Two

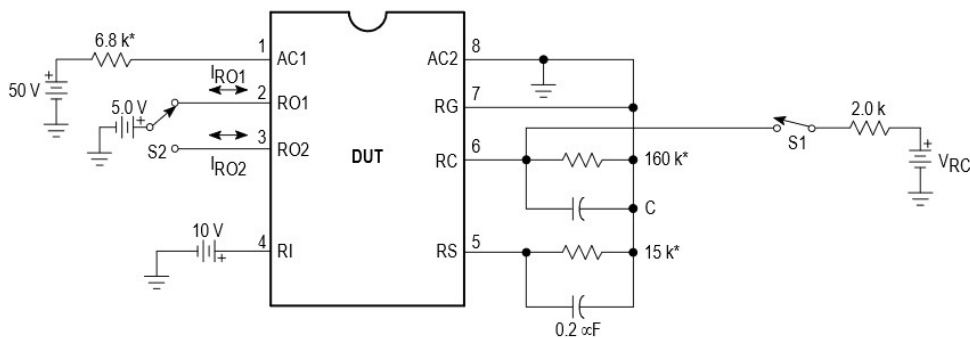

MC34017-1: C = 1000 pF\*  
 MC34017-2: C = 500 pF\*  
 MC34017-3: C = 1000 pF\*

\*Indicates 1% tolerance (5% otherwise)

With  $V_{RC} = 4.0\text{ V}$ , close S1. Switch S2 to Pin 2 and measure current at Pin 2 ( $I_{O1}$ ). Repeatedly switch  $V_{RC}$  between 4.0 V and 0 V until Pin 2 current changes polarity. Measure the opposite polarity current ( $I_{O2}$ ). Calculate:  $I_{RO1} = |I_{O1}| + |I_{O2}|$ . Switch S2 to Pin 3 and repeat. Calculate:  $I_{RO2} = |I_{O1}| + |I_{O2}|$ .

Figure 4. Test Three

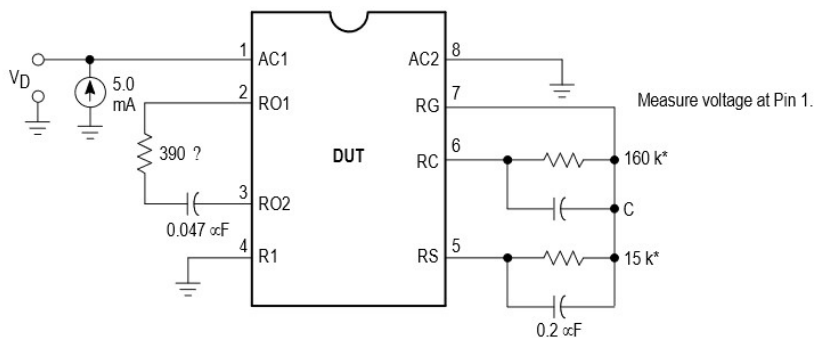

\*Indicates 1% tolerance (5% otherwise)

MC34017-1: C = 1000 pF\*  
 MC34017-2: C = 500 pF\*  
 MC34017-3: C = 1000 pF\*

### MC34017

Figure 5. Test Four

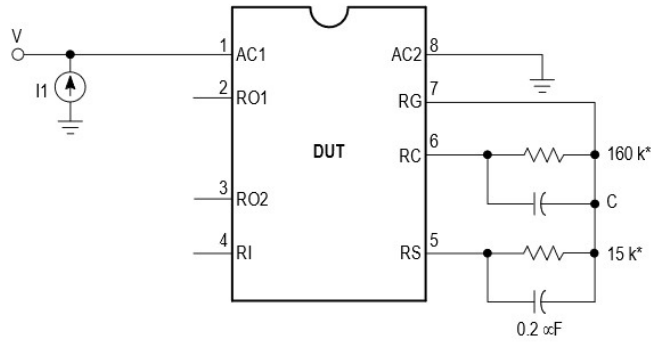

MC34017-1: C = 1000 pF\*  
 MC34017-2: C = 500 pF\*  
 MC34017-3: C = 1000 pF\*  
 \*Indicates 1% tolerance (5% otherwise)

a. Set I1 to 30 mA. Measure voltage at Pin 1 ( $V_{off}$ ).  
 b. Set I1 to 100 mA. Measure voltage at Pin 1 ( $V_{on}$ ).  
 (Each test < 30 ms)

Figure 6. Test Five

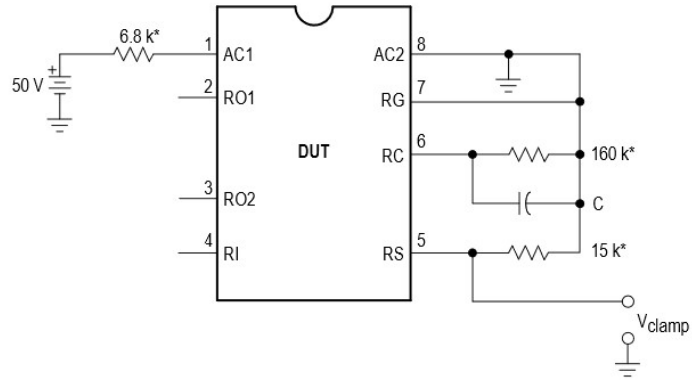

MC34017-1: C = 1000 pF\*  
 MC34017-2: C = 500 pF\*  
 MC34017-3: C = 1000 pF\*  
 \*Indicates 1% tolerance (5% otherwise)

Measure voltage at Pin 5 ( $V_{clamp}$ ).

Figure 7. Test Six

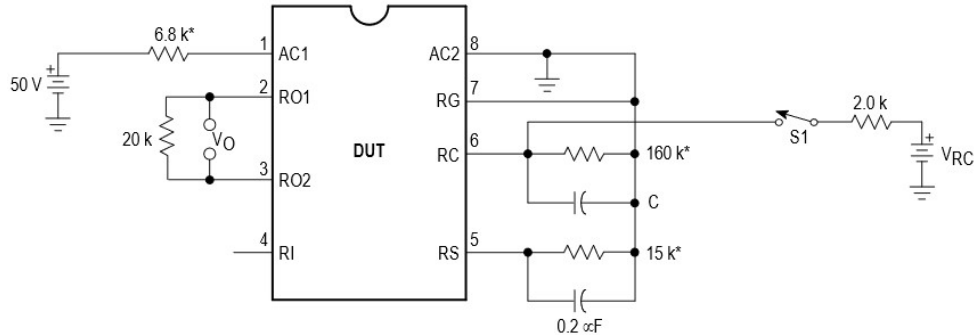

MC34017-1: C = 1000 pF\*  
 MC34017-2: C = 500 pF\*  
 MC34017-3: C = 1000 pF\*  
 \*Indicates 1% tolerance (5% otherwise)

With  $V_{RC} = 4.0$  V, close S1. Measure dc voltage between Pins 2 and 3 ( $V_{O1}$ ). Repeatedly switch  $V_{RC}$  between 4.0 V and 0 V until Pins 2 and 3 change state. Measure the new voltage between Pins 2 and 3 ( $V_{O2}$ ). Calculate:  $V_O = |V_{O1}| + |V_{O2}|$ .

# MC34017

## OUTLINE DIMENSIONS

**D SUFFIX**  
PLASTIC PACKAGE  
CASE 751-05  
ISSUE N

**NOTES:**

1. DIMENSIONING AND TOLERANCING PER ANSI Y14.5M, 1982.
2. CONTROLLING DIMENSION: MILLIMETER.
3. DIMENSIONS A AND B DO NOT INCLUDE MOLD PROTRUSION.
4. MAXIMUM MOLD PROTRUSION 0.15 (0.006) PER SIDE.
5. DIMENSION D DOES NOT INCLUDE DAMBAR PROTRUSION. ALLOWABLE DAMBAR PROTRUSION SHALL BE 0.127 (0.005) TOTAL IN EXCESS OF THE D DIMENSION AT MAXIMUM MATERIAL CONDITION.

DIM	MILLIMETERS		INCHES	
	MIN	MAX	MIN	MAX
A	4.80	5.00	0.189	0.196
B	3.80	4.00	0.150	0.157
C	1.35	1.75	0.054	0.068
D	0.35	0.49	0.014	0.019
F	0.40	1.25	0.016	0.049
G	1.27	BSC	0.050	BSC
J	0.18	0.25	0.007	0.009
K	0.10	0.25	0.004	0.009
M	0°	7°	0°	7°
P	5.80	6.20	0.229	0.244
R	0.25	0.50	0.010	0.019

**P SUFFIX**  
PLASTIC PACKAGE  
CASE 626-05  
ISSUE K

**NOTE 2:**

1. DIMENSION L TO CENTER OF LEAD WHEN FORMED PARALLEL.
2. PACKAGE CONTOUR OPTIONAL (ROUND OR SQUARE CORNERS).
3. DIMENSIONING AND TOLERANCING PER ANSI Y14.5M, 1982.

DIM	MILLIMETERS		INCHES	
	MIN	MAX	MIN	MAX
A	9.40	10.16	0.370	0.400
B	6.10	6.60	0.240	0.260
C	3.94	4.45	0.155	0.175
D	0.38	0.51	0.015	0.020
F	1.02	1.78	0.040	0.070
G	2.54	BSC	0.100	BSC
H	0.76	1.27	0.030	0.050
J	0.20	0.30	0.008	0.012
K	2.92	3.43	0.115	0.135
L	7.62	BSC	0.300	BSC
M	—	10°	—	10°
N	0.76	1.01	0.030	0.040

Motorola reserves the right to make changes without further notice to any products herein. Motorola makes no warranty, representation or guarantee regarding the suitability of its products for any particular purpose, nor does Motorola assume any liability arising out of the application or use of any product or circuit, a specifically disclaims any and all liability, including without limitation consequential or incidental damages. "Typical" parameters which may be provided in Motorola data sheets and/or specifications can and do vary in different applications and actual performance may vary over time. All operating parameters, including "Typical" must be validated for each customer application by customer's technical experts. Motorola does not convey any license under its patent rights nor the rights of others. Motorola products are not designed, intended, or authorized for use as components in systems intended for surgical implant into the body, or other applications intended to support or sustain life, or for any other application in which the failure of the Motorola product could create a situation where personal injury or death may occur. Should Buyer purchase or use Motorola products for any such unintended or unauthorized application, Buyer shall indemnify and hold Motorola and its officers, employees, subsidiaries, affiliates, and distributors harmless against all claims, costs, damages, and expenses, and reasonable attorney fees arising out of, directly or indirectly, any claim of personal injury or death associated with such unintended or unauthorized use, even if such claim alleges that Motorola was negligent regarding the design or manufacture of the part. Motorola and are registered trademarks of Motorola, Inc. Motorola, Inc. is an Equal Opportunity/Affirmative Action Employer.

**How to reach us:**  
**USA/EUROPE/Locations Not Listed:** Motorola Literature Distribution;  
 P.O. Box 20912; Phoenix, Arizona 85036. 1-800-441-2447 or 602-303-5454

**JAPAN:** Nippon Motorola Ltd.; Tatsumi-SPD-JLDC, 6F Seibu-Butsuryu-Cent  
 3-14-2 Tatsumi Koto-Ku, Tokyo 135, Japan. 03-81-3521-8315

**MFAX:** RMFAX0@email.sps.mot.com – TOUCHTONE 602-244-6609  
**INTERNET:** http://Design-NET.com

**ASIA/PACIFIC:** Motorola Semiconductors H.K. Ltd.; 8B Tai Ping Industrial Par  
 51 Ting Kok Road, Tai Po, N.T., Hong Kong. 852-26629298



?

MC34017/1

