

M67749SLR

335-360MHz, 12.5V, 7W, FM PORTABLE RADIO

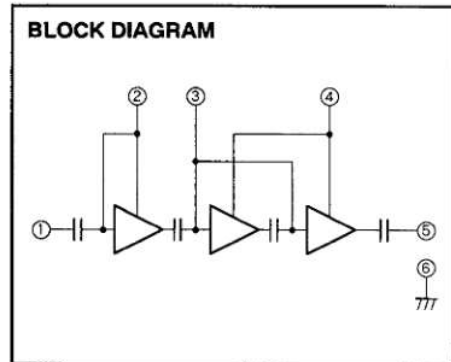
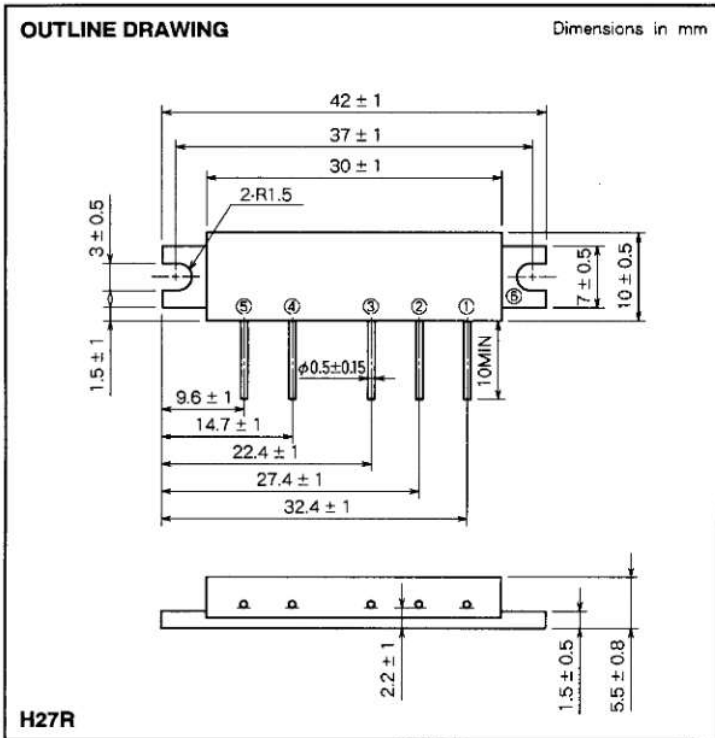

- PIN :
- ① Pin : RF INPUT
 - ② Vcc1 : 1st. DC SUPPLY
 - ③ VBB : BASE BIAS SUPPLY
 - ④ Vcc2 : 2nd. DC SUPPLY
 - ⑤ Po : RF OUTPUT
 - ⑥ GND : FIN

ABSOLUTE MAXIMUM RATINGS (T_c = 25°C unless otherwise noted)

Symbol	Parameter	Conditions	Ratings	Unit
V _{cc}	Supply voltage	V _{BB} ≤ 5V	16	V
V _{BB}	Base bias	V _{cc} ≤ 12.5V	6	V
I _{cc}	Total current		4	A
P _{in(max)}	Input power	Z _G = Z _L = 50 Ω, V _{cc1} ≤ 12.5V	40	mW
P _{O(max)}	Output power	Z _G = Z _L = 50 Ω	10	W
T _{c(OP)}	Operation case temperature		- 30 to 110	°C
T _{stg}	Storage temperature		- 40 to 110	°C

Note. Above parameters are guaranteed independently.

ELECTRICAL CHARACTERISTICS (T_c = 25°C unless otherwise noted)

Symbol	Parameter	Test conditions	Limits		Unit
			Min	Max	
f	Frequency range	P _{in} = 20mW V _{BB} = 5V V _{cc} = 12.5V Z _G = Z _L = 50 Ω	335	360	MHz
P _o	Output power		7		W
η _T	Total efficiency		38		%
2f _o	2nd. harmonic			- 25	dBc
3f _o	3rd. harmonic			- 30	dBc
ρ _{in}	Input VSWR			2.5	-
-	Load VSWR tolerance	V _{cc2} = 13.2V, V _{BB} = 5V P _{in} = 20mW P _O = 7W (V _{cc1} : controlled) Load VSWR = 20:1 (All phase), 2sec. Z _G = 50Ω	No degradation or destroy		-

Note. Above parameters, ratings, limits and conditions are subject to change.