

# HA12002

## Protector of Speakers and Power Amplifiers

The Hitachi monolithic IC HA12002 is designed for protecting power amplifiers and speakers in various amplifiers and receivers. The HA12002 is encapsulated in 8-pin single-in-line package.

### ■ FEATURES

- Built-in-relay driver
- Single power source
- Wide operating supply voltage range: (25 to 60V)
- Plus and minus voltage detections using one pin (both pins 3 and 4 possess the same functions and detect plus and minus voltages)
- AC voltage detector (pin-5)
- Circuit protection by plus voltage detection is provided by connecting D1 diode externally (pin-6). (See Note)
- Relay-on lag time adjustable by external applications.
- Short relay-off time (25ms typ under the standard external applications)

### ■ RECOMMENDED APPLICATIONS

- For speakers protection, use pin-3 (or pin-4) to detect setoff of quiescent output DC voltage and to turn the relay off.
- For protection of power amplifiers, use pin-3 (or pin-4) with an external thermo-sensitive device to detect the temperature increase and to turn the relay off.
- Power amplifiers can be protected by detecting overload and turning the relay off with pin-6.

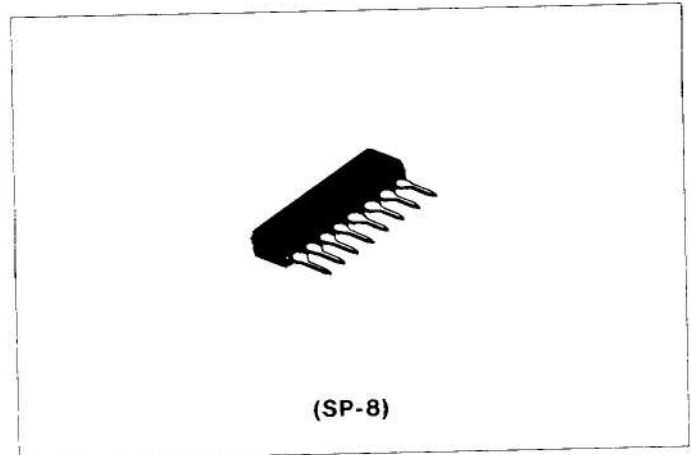

Note) Once relay is turned off, the relay off state continues until the power is switched off and then on again.

- In case of overload detection by constant-current drive or by constant-voltage drive using an external diode D1, the latch mechanism keeps the relay being on until the power is switched off.
- For prevention of pop noise at power off, use pin-5. AC voltage disappearance is immediately detected when the amp's switch has been off. This minimized the relay-off time and thus can prevent pop noise generated by mute-off time lag.

### ■ INTERNAL SCHEMATIC DIAGRAM AND RECOMMENDED EXTERNAL APPLICATIONS

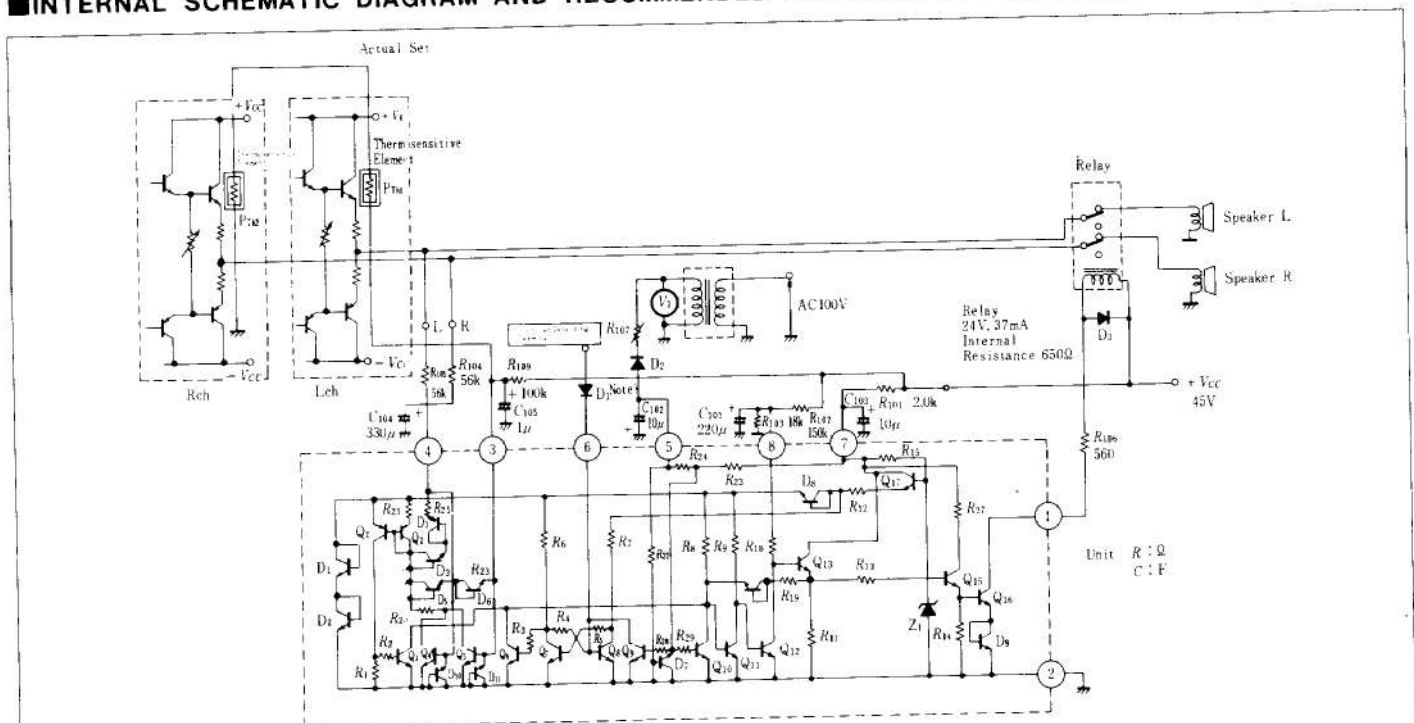

Note: When detecting an overload under a constant current drive, the latch functions without diode D<sub>1</sub>, however, when under a constant voltage drive, it functions only with D<sub>1</sub>.

■ BLOCK DIAGRAM

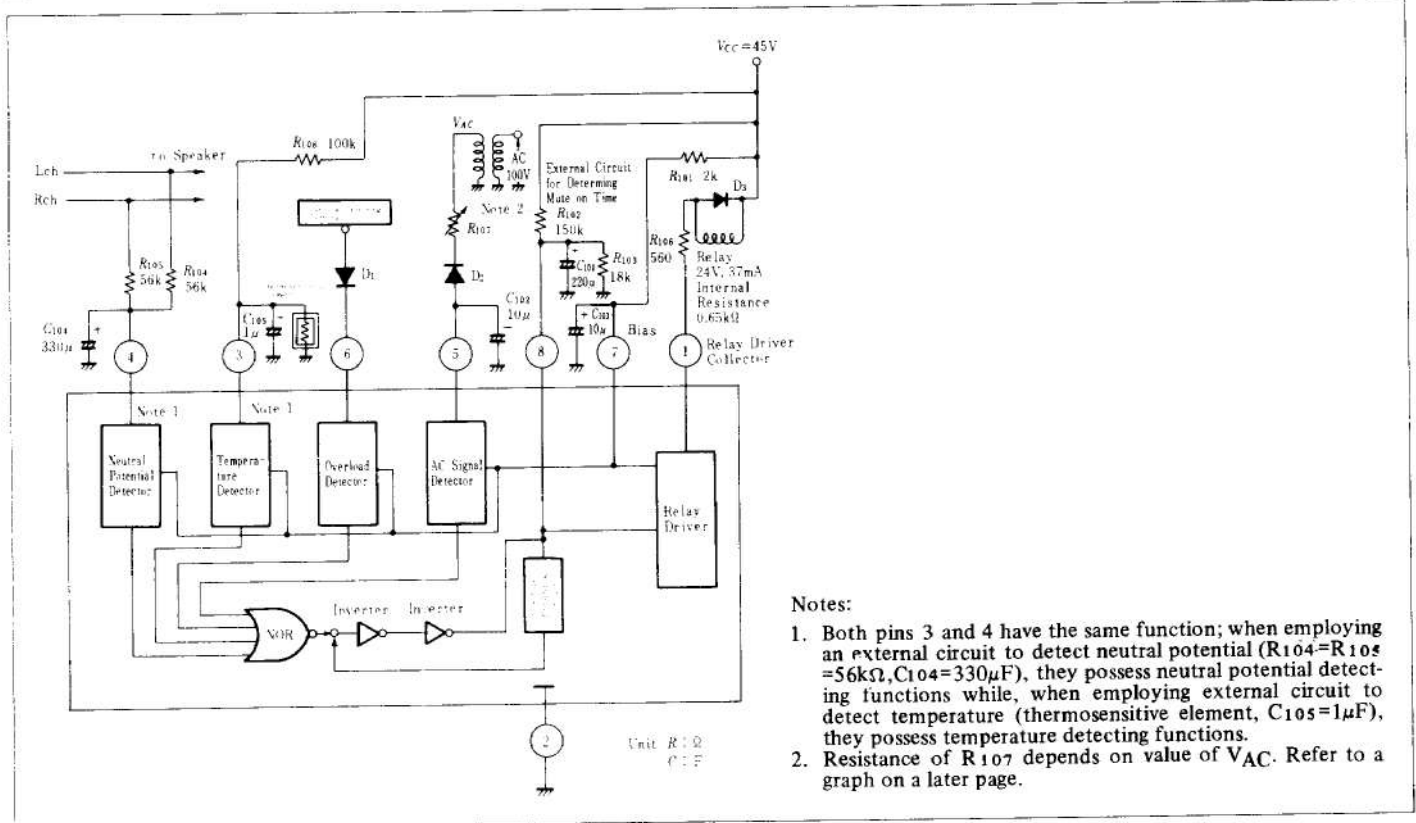

■ ABSOLUTE MAXIMUM RATINGS ( $T_a = 25^\circ C$ )

Item	Symbol	Rating	Unit
Power Dissipation	$P_T$	400*	mW
Operating Temperature	$T_{opr}$	-20 to +70	$^\circ C$
Storage Temperature	$T_{stg}$	-55 to +125	$^\circ C$
Supply Voltage (pin 1)	$V_{CC(max)}$	60	V
Max. Current for Pin 1	$I_{T(max)}$	80	mA
Max. Current for Pin 3	$I_{3(max)}$	$\pm 3^{**}$	mA
Max. Current for Pin 4	$I_{4(max)}$	$\pm 3^{**}$	mA
Max. Voltage for Pin 5	$V_{5(max)}$	-10	V
Max. Current for Pin 6	$I_{6(max)}$	3	mA
Max. Voltage for Pin 7	$V_{7(max)}$	8***	V
Max. Current for Pin 7	$I_{7(max)}$	25***	mA
Max. Voltage for Pin 8	$V_{8(max)}$	less than voltage of pin 7	V
Max. Current for Pin 8	$I_{8(max)}$	50	mA(peak)

Notes: \* : Value at  $T_a = 70^\circ C$

\*\* : Positive current denotes input current at pins 3 and 4, negative current denotes output current.

\*\*\* :  $V_{7(max)} = -8V$  is derived when driven by a constant voltage source, without any resistance. When applying current to  $V_{7}$  through a resistance  $V_{CC}$ , the max. value of the input current to pin 7 should be used instead of the above values.

■ ELECTRICAL CHARACTERISTICS (V<sub>CC</sub> = 45V)

Item	Symbol	Test Conditions	min.	typ.	max.	Unit
Threshold voltage at pin 3, positive side	+V <sub>th(3)</sub>	Apply positive voltage to pin 3 through an external resistance (56kΩ). Measure pin 3 voltage while pin 1 voltage changes from low (1.0V) to high (45V) during the above process.	0.89	1.20	1.61	V
Threshold voltage at pin 3, negative side	-V <sub>th(3)</sub>	Apply negative voltage to pin 3 through an external resistance (56kΩ). Measure pin 3 voltage while pin 1 voltage changes from low (1.0V) to high (45V) during the above process.	-1.86	-1.20	-0.84	V
Threshold voltage at pin 4, positive side	+V <sub>th(4)</sub>	Apply positive voltage to pin 4 through an external resistance (56kΩ). Measure pin 4 voltage while pin 1 voltage changes from low (1.0V) to high (45V) during the above process.	0.89	1.20	1.61	V
Threshold voltage at pin 4, negative side	-V <sub>th(4)</sub>	Apply negative voltage to pin 4 through an external resistance (56kΩ). Measure pin 4 voltage while pin 1 voltage changes from low (1.0V) to high (45V) during the above process.	-1.86	-1.20	-0.84	V
Threshold voltage at pin 6	V <sub>th(6)</sub>	Apply voltage to pin 6 through D <sub>1</sub> . Measure pin 6 voltage while pin 1 voltage change from low (1.0V) to high (45V) during the above process.	0.90	1.15	1.40	V
Threshold AC voltage at pin 5	V <sub>AC(5)</sub>	Apply AC voltage to pin 5 through D <sub>2</sub> . Measure AC voltage while pin 1 voltage change from low (1.0V) to high (45V) during the above process.	-	2.5	-	Vrms
Threshold voltage at pin 5	V <sub>th(5)</sub>	Apply voltage to pin 5 directly. Measure voltage of pin 5 while pin 1 voltage changes from low (1.0V) to high (45V) during the above process.	-1.8	-1.2	0	V
Current drain at pin 7	I <sub>(7)</sub>	Measure pin 7 input current when turning relay on.	16.5	18.5	20.5	mA

■ TEST CIRCUIT

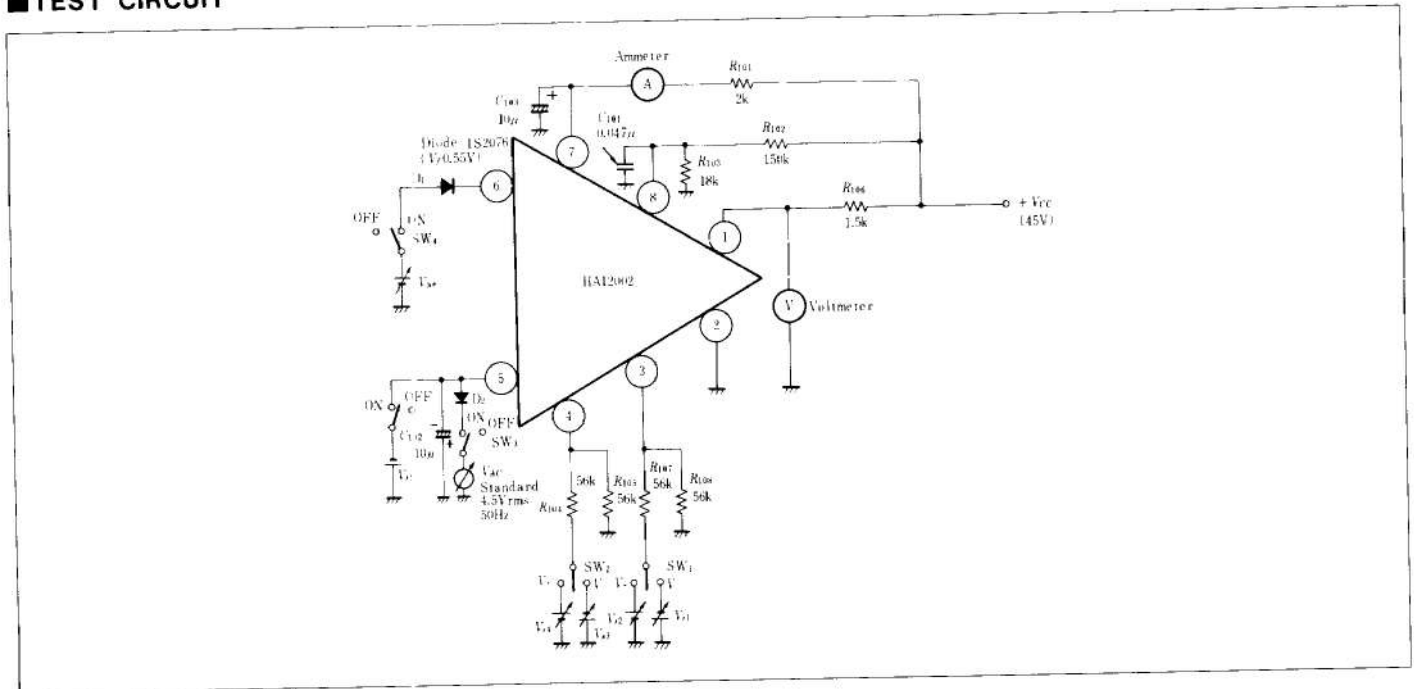

■ CHARACTERISTICS

This unit has been developed specifically for protection of speakers and power amplifiers. Following characteristics are delivered by giving careful consideration to the designing.

- Detection of Quiescent Output DC Voltage Setoff – pin-3 or 4

Both plus and minus sides DC voltage setoff can be detected with one power supply. This detection protects speakers by turning the relay off.

- Determination of Plus and Minus Threshold Voltages – pin-3 or 4

Threshold voltage for turning the relay on or off can be defined by external applications as follows.

Plus side threshold voltage +V<sub>th</sub> is defined as

$$+V_{th} = \left( 2 + \frac{R_{104}}{R_{110}} \right) V_a \quad \dots \text{eq. 1}$$

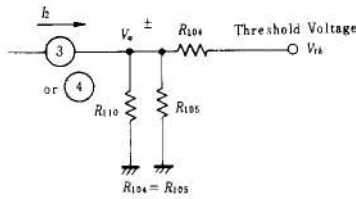

where  $V_{a+}$  is 0.57V typ, the threshold voltage with a plus voltage applied directly to pin-3 or 4.

Minus side threshold voltage  $-V_{th}$  is defined as

$$-V_{th} = - \left\{ V_{a-} \left( 2 + \frac{R_{104}}{R_{110}} \right) + I_2 \cdot R_{104} \right\} \dots \dots \text{eq. 2}$$

where  $V_{a-}$  is  $-0.28V$  typ, the threshold voltage with a minus voltage applied directly to pin-3 or 4 and where  $I_2$  is  $12.5\mu A$  typ, the pull-out current.

Plus and minus unbalanced thresholds can be corrected by adjusting  $R_{104}$  and  $R_{110}$  so as to satisfy

$$\left\{ V_{a-} \left( 2 + \frac{R_{104}}{R_{110}} \right) + I_2 \cdot R_{104} \right\} = \left( 2 + \frac{R_{104}}{R_{110}} \right) V_{a+} \dots \dots \text{eq. 3}$$

The plus-side threshold voltage has approximately 40mV hysteresis and the minus-side threshold voltage has approximately 300mV hysteresis.

**((Example Applications))**

$R_{104}$ ,  $R_{105}$  and  $R_{110}$  external resistor values can be defined to meet  $\pm V_{th}=1.8V$ ,

(a) From eq. 1 and  $\pm V_{th}=1.8V$ ,

$$1.8 = \left( 2 + \frac{R_{104}}{R_{110}} \right) \times 0.57 \quad (V)$$

Therefore  $R_{104}/R_{110}$  is defined as

$$\frac{R_{104}}{R_{110}} = 1.158$$

(b) From eq. 2 and  $-V_{th}=-1.8V$ ,

$$-1.8 = -0.28 \left( 2 + \frac{R_{104}}{R_{110}} \right) - 12.5 (\mu A) \times R_{104} (k\Omega) \quad (V)$$

$$R_{104} = \frac{1.8 - 0.884}{12.5} = 73.3 \quad (k\Omega)$$

$$R_{110} = 63.3 \quad (k\Omega)$$

Therefore, for  $V_{th}=1.8V$ ,

$$R_{104} = R_{105} = 75 \quad (k\Omega)$$

$$R_{110} = 62 \quad (k\Omega)$$

Minimum values of  $R_{104}$  and  $R_{105}$  can be defined by the maximum ratings of pin-3 and 4 ( $\pm 3mA$ ).

$$\frac{\pm V_{cc}}{R_{104} (105)} \leq \pm 3 \quad (mA)$$

Employing the recommended application values,  $R_{104} = R_{105} = 56k\Omega$ ,  $R_{110} = \infty$ , threshold voltage can be defined as follows.

$$(a) \quad +V_{th} = \left( 2 + \frac{56k\Omega}{\infty} \right) 0.57 = 1.14 \quad (V)$$

$$(b) \quad -V_{th} = -0.28 \left( 2 + \frac{56k\Omega}{\infty} \right) - 12.5\mu A \cdot 56k\Omega = -1.26(V)$$

• Temperature Increase Detection – pin-3 or 4

Pin-3 or 4 with an external thermo-sensitive device protects power amplifiers by detecting temperature increase and turning the relay off. Please see the recommended external applications.

• Relay-off by AC Voltage Disappearance Detection

The time from power amp's switch off to the relay off depends on the charging time determined by pin-5 voltage level, an external capacitor  $C_{102}$  and internal resistors  $R_{22}$ ,  $R_{23}$ ,  $R_{24}$ . When pin-5 voltage is  $-3.5V$  with the typical applications, relay-off time is defined as 25ms typ.

• Overload Detection – Pin-6

When using pin-6 as overload-detecting constant-current drive pin, the threshold current is  $110\mu A$  typ. Thus over  $110\mu A$  current causes the relay to go off. In this case, latch function operates without an external diode  $D_1$ . (When using constant-voltage drive,  $D_1$  is needed for latching.)

• Relay-on Time Lag – pin-8

To prevent pop noise at power on, time constant circuit at pin-8 lags relay-on after power amp's switch is turned on.

The relay-on time lag is defined as

$$t = \frac{R_{102} \cdot R_{103} \cdot C_{101}}{R_{102} + R_{103}} \cdot 1n \left\{ \frac{1}{1 - \frac{V_{th(8)} \cdot (R_{103} + R_{102})}{V_{cc} \cdot R_{103}}} \right\}$$

where  $V_{th(8)}$  is 2.65V typ, pin-8 threshold voltage.

• Wide Operating Supply Voltage Range – pin-7

$V_{cc}=25$  to  $60V$  can be obtained by an optimum  $R_{101}$  value.

