

AUDIO FREQUENCY AMPLIFIER APPLICATIONS.

FEATURES:

- . Complementary to 2SA1144.
- . Small Collector Output Capacitance : $C_{ob}=1.8\text{pF(Typ.)}$
- . High Transition Frequency : $f_T=200\text{MHz(Typ.)}$

MAXIMUM RATINGS ($T_a=25^\circ\text{C}$)

CHARACTERISTIC	SYMBOL	RATING	UNIT
Collector-Base Voltage	V_{CB0}	150	V
Collector-Emitter Voltage	V_{CE0}	150	V
Emitter-Base Voltage	V_{EB0}	5	V
Collector Current	I_C	50	mA
Base Current	I_B	5	mA
Collector Power Dissipation ($T_c=25^\circ\text{C}$)	P_C	10	W
Junction Temperature	T_j	150	$^\circ\text{C}$
Storage Temperature Range	T_{stg}	-55~150	$^\circ\text{C}$

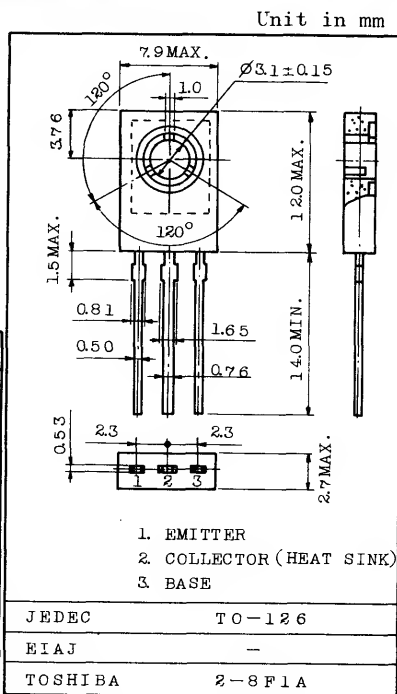

Mounting Kit No. AC46C

Weight : 0.72g

ELECTRICAL CHARACTERISTICS ($T_a=25^\circ\text{C}$)

CHARACTERISTIC	SYMBOL	TEST CONDITION	MIN.	TYP.	MAX.	UNIT
Collector Cut-off Current	I_{CB0}	$V_{CB}=150\text{V}, I_E=0$	-	-	0.1	μA
Emitter Cut-off Current	I_{EB0}	$V_{EB}=5\text{V}, I_C=0$	-	-	0.1	μA
Collector-Emitter Breakdown Voltage	$V_{(BR)CE0}$	$I_C=1\text{mA}, I_B=0$	150	-	-	V
DC Current Gain	h_{FE} (Note)	$V_{CE}=5\text{V}, I_C=10\text{mA}$	80	-	240	
Collector-Emitter Saturation Voltage	$V_{CE(sat)}$	$I_C=10\text{mA}, I_B=1\text{mA}$	-	-	1.0	V
Base-Emitter Voltage	V_{BE}	$V_{CE}=5\text{V}, I_C=10\text{mA}$	-	-	0.8	V
Transition Frequency	f_T	$V_{CE}=10\text{V}, I_C=10\text{mA}$	-	200	-	MHz
Collector Output Capacitance	C_{ob}	$V_{CB}=10\text{V}, I_E=0, f=1\text{MHz}$	-	1.8	-	pF

Note: h_{FE} Classification. O:80~160, Y:120~240

2SC2704

